

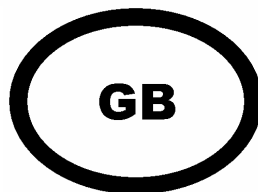
These instructions contain operating information and should be left with the unit.

**Vapac**<sup>®</sup>

**Electrode Boiler Units**  
**LExxLC Range**  
**Installation & Operation Manual**

Edition 1.3.2

**VapaNet**



**Installation in countries covered by EC Directives:**

This product will meet the requirements of the Low Voltage Safety Directive 73 / 23 EEC and the EMC Directive 89 / 336 EEC when installed in accordance with the instructions contained in this manual.

Failure to comply with these instructions may invalidate the manufacturer's warranty or any certificate/declaration of conformance requested to be supplied with the unit.

**CONTENTS**

1.0	Installation.....	4
1.1	Vapac LE unit dimensions.....	4
1.1.1	LExxLC weights.....	6
1.2	Positioning the steam pipes.....	6
1.2.1	General.....	6
1.2.2	Steam Hose Connection.....	6
1.3	Plumbing Considerations.....	7
1.4	Electrical Connections.....	8
1.4.1	Important E.M.C. Considerations.....	8
1.4.2	Power Supply Connection.....	9
1.4.3	Electrical Connections.....	9
1.4.4	Cable Entry Provision.....	9
1.4.5	Vapac Control Circuit Transformer.....	9
1.4.6	RDU Connection (If fitted).....	9
1.4.7	Power Connection Diagrams.....	9
1.5	Cylinder Electrical demand loads.....	10
1.5.1	LExxLC Units.....	10
1.6	Control Circuit Connections.....	11
1.6.1	Control Circuit Wiring.....	11
1.6.2	On/Off Control.....	11
1.6.3	Proportional Control.....	11
1.6.4	Control Signal Selection.....	12
1.6.5	Security Circuit / E.P.O. Shutdown.....	12
2.0	Start-Up / Operation.....	13
2.0.1	Start-up check list.....	14
2.0.2	Start-Up Instructions.....	14
2.0.3	Commissioning/Start-Up.....	14
2.0.4	Features of VAPANET Electrode Boiler Unit.....	14
2.1	Service Advice.....	15
2.1.1	Procedure for Cylinder Exchange.....	15
2.1.2	Typical Cylinder / Electrode Layouts.....	15
2.2.1	Feed Valve with Strainer.....	16
2.2.2	Drain Pump.....	16
3.0	Location of Indicators and Controls.....	17
3.1	Positioning of Indicators and Controls on Vapac® Vapanet® LELC Units.....	17
3.2	Initial Set-up.....	18
3.3	Normal Run / Standby / Start-up – No User Intervention Required.....	19
3.4	Fault / Service Indications – Requiring Operator Intervention.....	20
3.3	Facia Label symbols.....	21
4.0	Trouble-shooting Check List.....	22
5.0	Wiring diagram.....	23
Appendix 1.		
	A Guide to Positioning Steam Pipes:.....	26
Appendix 2.		
	A Guide to Positioning Multipipes:.....	28

## Important Installation Points

The unit must be installed to comply with national regulations and/or codes of practice. A qualified electrician must carry this out.

Ensure at least 1000 mm clear front access to the electrical and steam sections.

Do not locate the cabinet where the ambient temperature around the unit could exceed 35° C; or fall below 5° C e.g., an unventilated roof mounted enclosure – see minimum space / ventilation requirements pages 4 & 5.

Do not locate the cabinet where a ladder is required for service access as this could make servicing and cylinder service or exchange hazardous.

Make sure steam line(s) have adequate slope (min 12%) for condensate drainage and use condensate separators if the pipe is lower than the unit.

Provide adequate support to prevent sags developing in flexible steam lines, which can fill with water and create a "trap".

Do not locate vented drain directly under the cabinet – See page 7.

## Important Electrical Connection Items

Before commissioning the unit, check that all electrical (power) connections - including those at the terminals and contactor are tight.

Check that the transformer primary winding connection is correct for the supply voltage at Vapac terminals A1 & A2.

The Vapac transformer must not be used to power other equipment.

To comply with EMC aspects see recommendations on page 8.

Use a high-limit humidistat to ensure positive interruption of unit operation when over-humidification is detected (see page 12).

It is important to note that the control signal input to terminal 5 is connected to ground at the Vapac control PCB.

**NB:** Care should be taken if the controller output is also referenced to earth, as incorrect connection will lead to damage to the controller and or the Vapac control PCB.

## Important Maintenance Items

Only a qualified electrician should carry out maintenance.

The boiler contains hot water, and must be drained before any maintenance is carried out on the steam section. This should be done prior to isolating the power, and removing the front access panel.

**ESD SENSITIVE DEVICES USED ON PCB. ENSURE ANTI-STATIC PRECAUTIONS ARE TAKEN WHEN REMOVING OR REPLACING PCB'S.**

## 1.0 Installation

### Do's

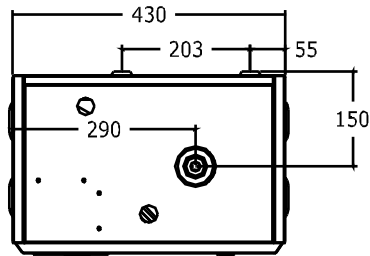
- Do** mount the unit as close to the steam distribution pipe(s) as possible.
- Do** mount the unit at a height convenient for reading the display window.
- Do** ensure adequate side ventilation (min 80 mm).
- Do** ensure adequate service access to the front of the unit (min 1000 mm).
- Do** ensure adequate service access below the unit (min 1000 mm).
- Do** ensure that the holes in the rear top panel remain unobstructed to allow a free flow of air.
- Do** use the marking on the side of the carton as a template to mark the mounting hole positions.
- Do** remove the cylinder, if necessary, to access the mounting holes in the back of the steam section.
- Do** use M6 projecting type wall bolts or equivalent to mount the unit in position.

### Don'ts

- Don't** mount the unit close to sources of strong electromagnetic emissions e.g. variable speed lift motor drives, kVa transformers etc.
- Don't** mount the unit in an unventilated enclosure.
- Don't** mount in a position requiring ladder access to the unit.
- Don't** mount the unit behind a false ceiling or other situation where an unusual malfunction (e.g. water leak) would cause damage.
- Don't** mount the unit in an area which will be hosed down.
- Don't** install the unit where the ambient temperature can exceed 35°C; or fall below 5°C.
- Don't** mount the unit inside a cold-room or other place where temperature and humidity conditions can cause condensation on electrical components.
- Don't** mount the unit where the sound of a contactor opening/closing and water flow in a pipe would be unacceptable e.g. libraries, private apartments, etc.

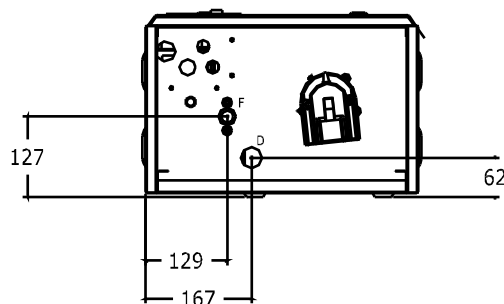
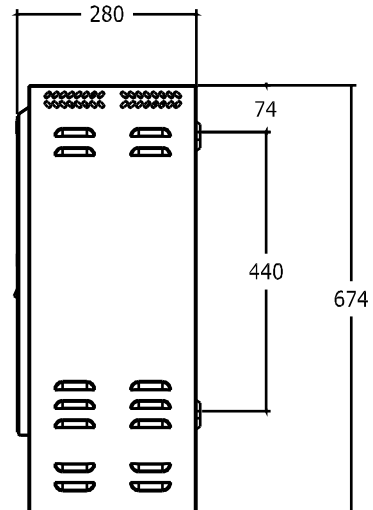
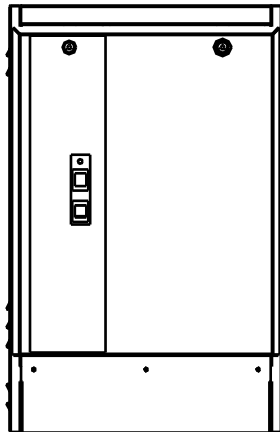
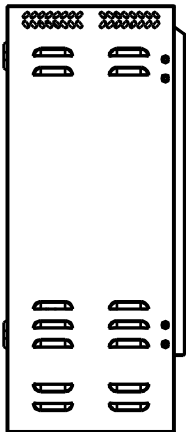
## 1.1 Vapac LE unit dimensions

### Cabinet Sz 1 (5 – 18 kg/h Models)



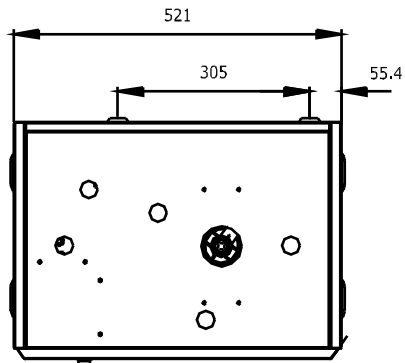
Left:  
Top View Showing Steam O/let position and wall mounting points.

Below: Side View showing wall mounting points.



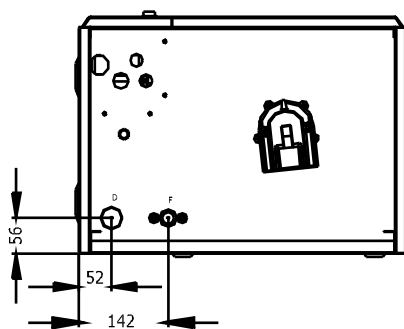
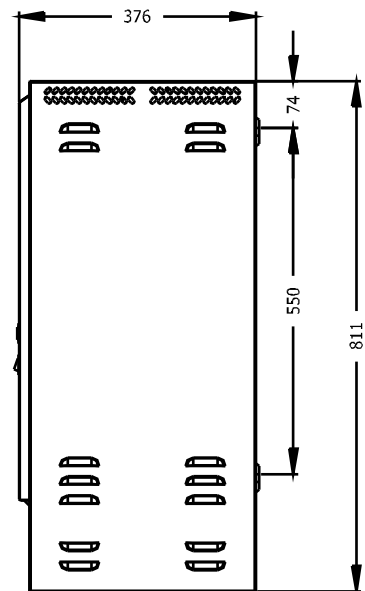
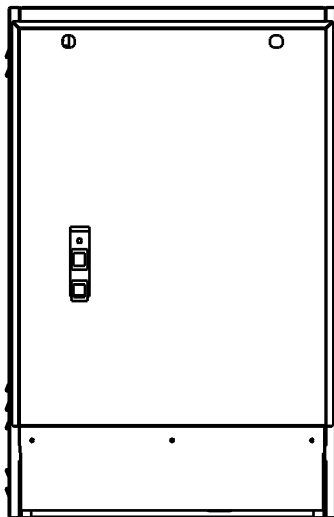
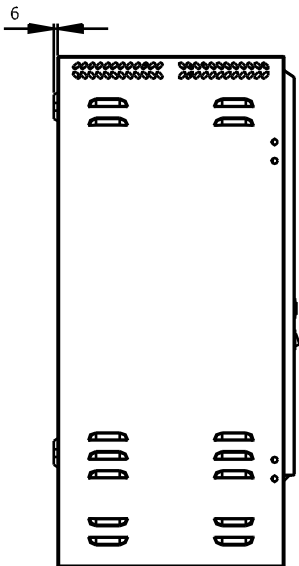
Left:  
Bottom View Showing "F" (Feed connection) 3/4" BSP male connection for flexible hose provided with unit. "D" (Drain connection) 35 mm pipe.

Cabinet Sz 2 (30 – 55 kg/h Models)



Left:  
Top View Showing Steam  
O/let position and wall  
mounting points

Below: Side View  
showing wall  
mounting points.



Left:  
Bottom View Showing  
“F” (Feed connection)  $\frac{3}{4}$ ”  
BSP male connection for  
flexible hose provided  
with unit.  
“D” (Drain connection)  
35 mm pipe.

**1.1.1 LExxLC weights**

The unit dry weight is the delivered unit with no water in unit, the wet weight is the operational weight when the unit is running.

Vapanet model	Dry Kg	Wet Kg
LE05LC	34	48
LE09LC	35.5	50.0
LE18LC	39	65.5
LE30LC	40	66.5
LE45LC / LE55LC	45	72

**1.2 Positioning the steam pipes**

**1.2.1 General**

Steam pipes should be positioned as shown below, allowing a minimum rate of fall back to the unit of 12% to allow the free flow of condensate back to the unit. If the above fall is not possible, then condensate separators must be fitted as shown in appendix 1.

The position of the steam pipe or multipipe in a air-conditioning system relative to other items such as bends, filters, heat exchangers, etc., is critical. The steam pipe must not be located closer to such items, than the entrainment distance and must be decided by the design engineer responsible for the project.

**Do's**

- Do** obtain project engineer's instruction/drawing for chosen location of pipe.
- Do** obtain project engineer's instruction/drawing for pipe position relative to the top & bottom of the duct (or sides if airflow is vertical).
- Do** check if alternative slope of Ø35mm steam pipe has been specified.
- Do** use bracket/lug on the end of Ø54mm steam pipes for extra support.

**1.2.2 Steam Hose Connection**

**Do's**

- Do** use Vapac steam hose or well insulated copper pipe.
- Do** keep steam hose as short as possible (under 2m for max efficiency).
- Do** arrange to have a vertical rise immediately over the unit of at least 300mm.
- Do** use the full height available between the unit and steam pipe to provide maximum slope (min 12-20%) for condensate to drain back to the steam cylinder (or down to a condensate separator). Always provide a continuous slope.
- Do** provide adequate support to prevent sagging.
  - a) fit pipe clips every 30-50cm
  - or b) support straight lengths on cable trays or in heat resistant plastic pipe.

**Do** ensure radius hose bends are fully supported to prevent kinks developing when in service.

**Do** add extra insulation to steam hose for longer runs (2m-5m) and in cold ambient conditions to avoid excess condensate and reduction in delivered output.

**Don'ts**

**Don't** allow steam hose to develop kinks or sags.  
**Don't** include horizontal runs or 90° elbows in the steam line.

Steam Distribution Pipe requirement		
Electrode Boiler Unit Model	LE05LC LE09LC LE18LC	LE30LC LE45LC LE55LC
35mm ? Pipe No.	1	-
54mm ? Pipe No.	-	1
*Duct Pressure Pa.	+1000 -600	

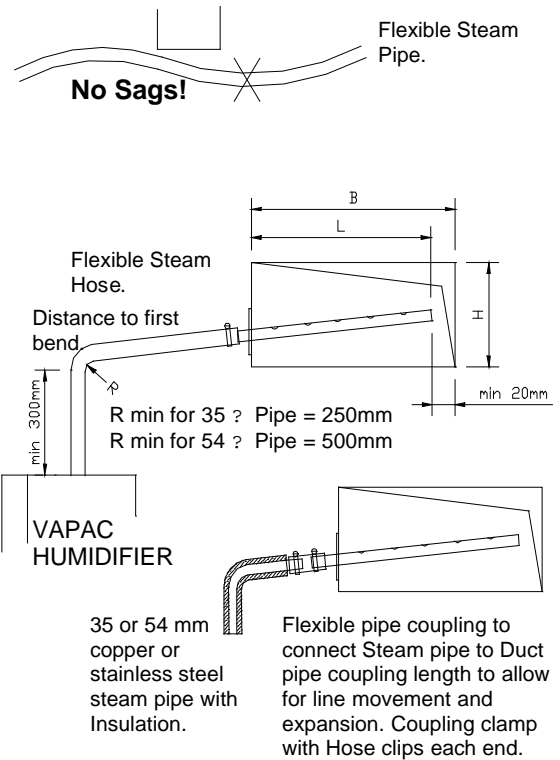


Fig 6

35mm ? Pipe Selection		54mm ? Pipe Selection	
Duct width B mm	In-duct Length L mm	Duct width B mm	In-duct Length L mm
320-470	300		
470-620	450		
620-770	600		
770-920	750	700-950	650 (1.8)
920-1070	900	950-1450	900 (2.2)
1070-1200	1050	1450+	1400 (3.2)

**For guidance on positioning of steam pipes see Appendix 1.  
 For guidance on use of Multipipes see Appendix 2.**

### 1.3 Plumbing Considerations

#### 1.3.1 Cold water supply

##### General

The Vapanet range of electrode boilers is capable of operating with a range of "raw mains" water quality. The water supply should be within the following limits:-

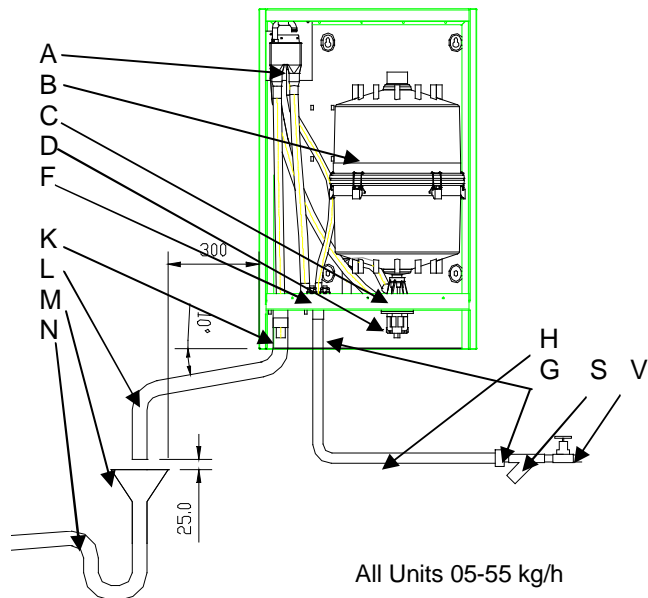
<b>Hardness</b>	<b>50 – 500 ppm</b>
<b>Conductivity</b>	<b>80 – 1000 µS*</b>
<b>PH</b>	<b>7.3 – 8.0</b>
<b>Silica</b>	<b>0</b>
<b>Pressure of between 1 - 8 bar.</b>	
<b>* LE55LC conductivity &gt;200 µS</b>	

In addition, if stainless steel electrodes are used the chlorine level must not exceed 170 ppm.

Water Supply rates	
1.20 l/min	LE05LC
1.20 l/min	LE09LC
1.20 l/min	LE18LC
2.50 l/min	LE30LC
2.50 l/min	LE45LC & LE55LC

##### Do's

- Do** install a stop-valve/Shut-off valve and a strainer close to the unit.
- Do** provide a water supply with sufficient pressure and pipe size to ensure an adequate flow rate to all units connected to the system.
- Do** use the flexible hose connection with nylon nut provided.



All Units 05-55 kg/h

ALL Dimensions in mm

##### Don'ts

**Don't** use a wrench or other tool to tighten the water supply connection - the nylon nut and rubber washer provided, should only require tightening by hand to effect a seal. If water seepage occurs, undo the nut to wipe the washer clean and re-seat it.

#### 1.3.2 Drain connection

##### General

##### Do's

**Do** ensure metal drain and supply water pipework is grounded electrically close to the unit (a ground/earth stud is positioned on the underside of the cabinet).

Drain capacity per cylinder	= pump discharge rate of max 16.8 l/min at 50 Hz.
Power supply	17.2 l/min at 60 Hz.

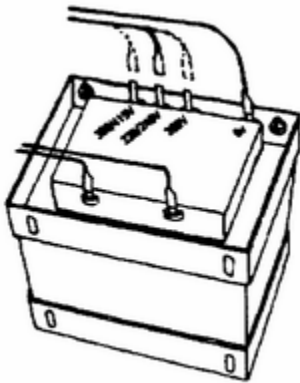
##### Do's

- Do** use copper or plastic pipe rated for 110 °C.
- Do** arrange to discharge drain water from the unit into a trapped and vented drain at a position where flash steam rising from the drain line vent will not pose a problem for the Vapac or other equipment.
- Do** provide adequate fall for the drain pipework to allow free flow of water drained from each unit.
- Do** ensure drain line pipe size will accommodate water being drained at the same time from all the Vapac units which are connected to it.

##### KEY: -

- A Tundish Fill-cup
- B Steam Cylinder
- C Feed Drain Manifold
- D Drain Pump
- F Feed Solenoid Valve
- G Water Connection 3/4" BSP
- H Flexible hose 3/4" BSP
- K 35Ø Steam Hose coupling and Hose Clips
- L 35Ø copper or plastic Drain for 110°C Water with supports
- M Tundish
- N U-trap side exit
- S Optional Strainer
- V Isolation stop cock

1.4 Electrical Connections



**Important Power Connection Information**

Vapac 24V secondary Transformer Primary supply connections:  
 Vapac units are wired to allow connection to alternative site Voltages.  
 Make the following simple checks before connecting the power supply:-  
 Move the RED connection on the VAPANET transformer primary winding circuit to the position marked with the supply Voltage that is to be connected between VAPANET power terminals A1 and A2.  
 The transformer primary circuit terminal positions are clearly marked:- 200V, 230V, 380, 415 & 440V. **If the actual (measured) site voltage is 400v the preferred tapping is 380V.**

**Note:**

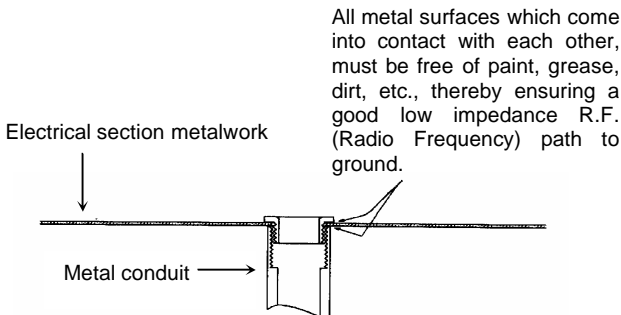
- 24 V a.c. Control Circuit - 3.15 A 20 mm (T – Time Lag) fuse (Pt. N<sup>o</sup>. 1080096) mounted on VAPANET Echelon PCB (Pt. N<sup>o</sup>.1150655).
- Transformer Primary Circuit and RDU. - Two fuses protect the control circuit on Single cylinder units F1 2.0A (slow blow) (Pt. No. 1080095) mounted in fuse-terminal holder; protects transformer primary and RDU unit if fitted. F2 500 mA 20 mm (F - Quick blow) fuse (Pt No. 1080054) mounted in fuse-terminal holder; protects transformer primary and pump.
- 230V ac Pump Supply. - The pump is fed from the main transformer via a 230 volt auto winding. The pump is protected by fuses F1 and F2 above feeding the transformer primary.

1.4.1 Important E.M.C. Considerations

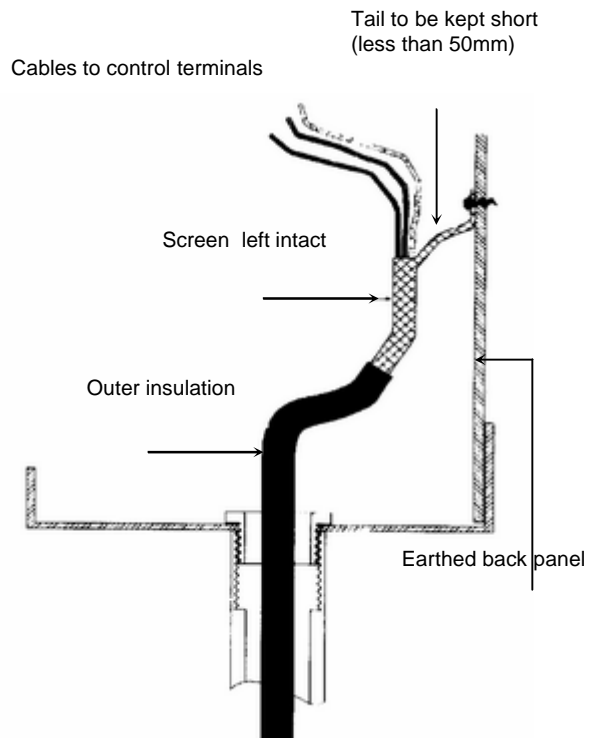
Use a dedicated, earthed metal conduit for both the control signal cable and the security circuit cables along their entire length - they may share the same conduit where practicable. The earth must be made by "metal-to-metal" contact and should be a good RF (Radio Frequency) earth.

The control and security circuit connections should be run in screened cable with the screen grounded at the VAPANET end (onto the electrical section back panel). The screen should be maintained as close as possible to the cable ends and any tail between the screen and the earth point must be kept short (50 mm maximum).

**Control Cable / Security Circuit Conduit Entry Arrangement**



**Control Cable / Security Circuit Screening Arrangement**



**1.4.2 Power Supply Connection**

The unit requires the following connections:

Single Phase Units (5 to 9 kg/h)

Supply L1 to Terminal A1 Neutral to A2:

Two Phase Units: (5 to 9 kg/h)

Supply L1 to Terminal A1 Supply L2 to Terminal A2:

Three Phase Units: (18 to 55 kg/h)

Supply L1 to Terminal A1; L2 to A2; L3 to A3:

In addition all units require a protective Earth to be connected to the main earth bar.

**NB**

**Neutral connection is only required if an RDU is fitted (Requirement must be stated at time of order, as additional terminals & cabling needs to be built in – which cannot be retro-fitted, as this will invalidate EMC testing).**

**1.4.3 Electrical Connections**

The wiring to the Vapac should be done by a qualified electrician. The external over current protection and wiring should comply with the appropriate Regulations and Codes of Practice.

**Important:** Make sure the connection to the primary Voltage winding of the Vapac transformer matches the supply Voltage which is to be connected between Vapac terminals A1 & A2. If the actual (measured) site voltage is 400v the preferred tapping is 380V.

A fused disconnect/isolator or MCB should be used to disconnect the supply from all electrodes simultaneously.

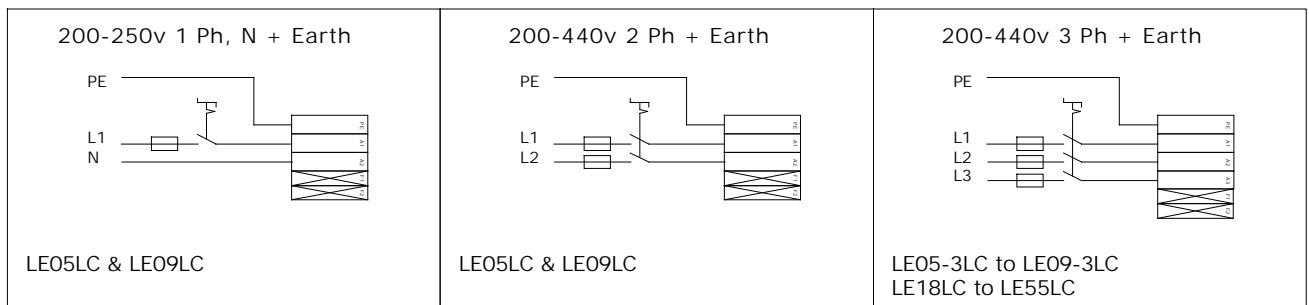
This must be sized to suit the total maximum phase/line current of the unit and should be located adjacent to the Vapac cabinet or within easy reach and readily accessible.

In Vapac VAPANET units terminals A1, A2 and A3 are for the power supply connections (see diagrams page 11).

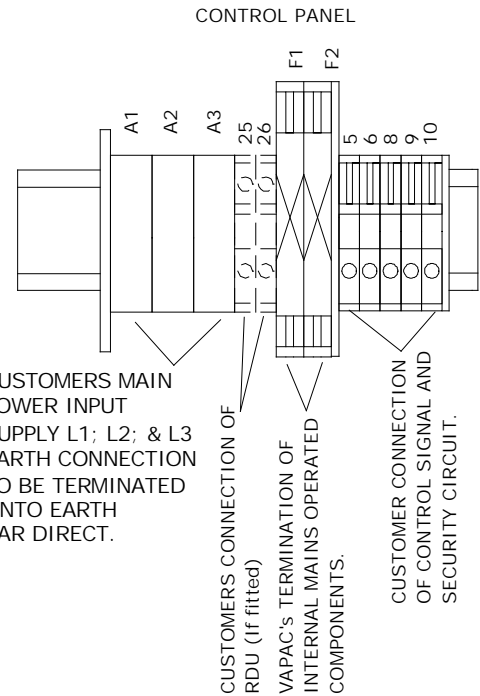
**1.4.4 Cable Entry Provision**

Cable glands must be used to ensure cables are held securely at the entry position. Remove blanking grommets from the drain tray and fit suitably sized cable glands as required.

**1.4.7 Power Connection Diagrams**



- Notes:-**
1. All units must have a PE earth connection connected to the unit's Earth Bar.
  2. Unit with N.A. in the following tables means NOT AVAILABLE there is not a unit available to run at the voltage and phases shown. Please check that the correct model reference is ordered and installed, for the low or high voltage required, and at the desired steam output.
  3. Standard design is for 50 Hz supplies. Design for 60 Hz also available - 60 Hz supply must be specified with order as the standard pump is only 50Hz.



**1.4.5 Vapac Control Circuit Transformer**

The internal control circuit of the Vapac unit operates at 24Vac - the transformer secondary is set at 24V.

As standard the Vapac VAPANET includes a transformer with alternative primary winding options 200V, 230, 380, 415, and 440V and requires on site adjustment to match it to the Voltage connected to Vapac terminals A1 and A2.

The transformer also has a 9V secondary tapping which provides power to the VAPANET 1150630 PCB.

**Important:** The Vapac transformer must **NOT** be used to power other equipment or the warranty will be invalidated.

**1.4.6 RDU Connection (If fitted).**

Vapac terminals 25 & 26 can be included to provide a 230Vac electrical supply for the fan motor in the RDU (Room Distribution Unit) when stated at time of order.

**Note:** For specific information regarding the installation of an RDU please see Appendix 3 of the manual (supplied with the RDU).

1.5 Cylinder Electrical demand loads

1.5.1 LExxLC Units

Model Ref.	LE05LC							LE09LC							
Nominal Output	Kg/hr	5	5	5	5	5	5	9	9	9	9	9	9		
Nominal Output	lb/hr	11	11	11	11	11	11	19.8	19.8	19.8	19.8	19.8	19.8		
Voltage	V	200	230	380	400	415	440	200	230	380	400	415	440		
Power input rating	Kw	3.71	3.72	3.8	3.81	3.75	3.77	6.76	6.68	6.7	6.86	6.72	6.7		
Electrical Supply	Ph's	Ph+N or 2Ph	Ph+N or 2Ph	Ph+N or 2Ph	Ph+N or 2Ph	Ph+N or 2Ph	Ph+N or 2Ph	Ph+N or 2Ph	Ph+N or 2Ph	Ph+N or 2Ph	Ph+N or 2Ph	Ph+N or 2Ph	Ph+N or 2Ph		
No. of electrodes		2	2	2	2	2	2	2	2	2	2	2	2		
Full load Current	A	19.5	17	10.5	10	9.5	9	35.5	30.5	18.5	18	17	16		
Maximum overcurrent	A	29.25	25.5	15.75	15	14.25	13.5	53.25	45.75	27.75	27	25.5	24		
Fuse Rating/phase	A	32	32	20	20	16	16	63	50	32	32	32	32		
Supply cable terminals	mm2	10	10	10	10	10	10	16	16	16	16	16	16		
Wiring diagram															
Cabinet size		1							1						
Model Ref.	LE05-3LC							LE09-3LC							
Nominal Output	Kg/hr	5	5	5	5	5	5	9	9	9	9	9	9		
Nominal Output	lb/hr	11	11	11	11	11	11	19.8	19.8	19.8	19.8	19.8	19.8		
Voltage	V	200	230	380	400	415	440	200	230	380	400	415	440		
Power input rating	Kw	3.79	3.79	3.76	3.96	3.77	3.99	6.76	6.83	6.9	6.93	6.85	6.9		
Electrical Supply	Ph's	3Ph	3Ph	3Ph	3Ph	3Ph	3Ph	3Ph	3Ph	3Ph	3Ph	3Ph	3Ph		
No. of electrodes		3	3	3	3	3	3	3	3	3	3	3	3		
Full load Current	A	11.5	10	6	6	5.5	5.5	20.5	18	11	10.5	10	9.5		
Maximum overcurrent	A	17.25	15	9	9	8.25	8.25	30.75	27	16.5	15.75	15	14.25		
Fuse Rating/phase	A	25	20	16	16	10	10	32	32	20	20	20	16		
Supply cable terminals	mm2	10	10	10	10	10	10	10	10	10	10	10	10		
Wiring diagram															
Cabinet size		1							1						
Model Ref.	LE18LC							LE30LC							
Nominal Output	Kg/hr	18	18	18	18	18	18	30	30	30	30	30	30		
Nominal Output	lb/hr	39.6	39.6	39.6	39.6	39.6	39.6	66	66	66	66	66	66		
Voltage	V	200	230	380	400	415	440	200	230	380	400	415	440		
Power input rating	Kw	13.36	13.47	13.48	13.53	13.35	13.43	22.43	22.38	22.25	22.43	22.25	22.5		
Electrical Supply	Ph's	3Ph	3Ph	3Ph	3Ph	3Ph	3Ph	3Ph	3Ph	3Ph	3Ph	3Ph	3Ph		
No. of electrodes		3	3	3	3	3	3	6	6	3	3	3	3		
Full load Current	A	40.5	35.5	21.5	20.5	19.5	18.5	68	59	35.5	34	32.5	31		
Maximum overcurrent	A	44.55	39.05	23.65	22.55	21.45	20.35	74.8	64.9	39.05	37.4	35.75	34.1		
Fuse Rating/phase	A	50	50	32	32	25	25	80	80	50	50	40	40		
Supply cable terminals	mm2	16	16	16	16	16	16	35	35	16	16	16	16		
Wiring diagram															
Cabinet size		1							2						
Model Ref.	LE45LC							LE55LC							
Cylinder		1	1	1	1	1	1	1	1	1	1	1	1		
Nominal Output	Kg/hr	44	45	45	45	45	45	55	55	55	55	55	55		
Nominal Output	lb/hr	96.8	99	99	99	99	99	NA	NA	121	121	121	121		
Voltage	V	200	230	380	400	415	440	200	230	380	400	415	440		
Power input rating	Kw	32.66	33.39	33.85	33.65	33.54	33.39	NA	NA	41.37	40.91	41.07	41.37		
Electrical Supply	Ph's	3Ph	3Ph	3Ph	3Ph	3Ph	3Ph	NA	NA	3Ph	3Ph	3Ph	3Ph		
No. of electrodes		6	6	6	6	6	6	NA	NA	6	6	6	6		
Full load Current	A	99	88	54	51	49	46	NA	NA	66	62	60	57		
Maximum overcurrent	A	108.9	96.8	59.4	56.1	53.9	50.6	NA	NA	72.6	68.2	66	62.7		
Fuse Rating/phase	A	125	125	63	63	63	63	NA	NA	80	80	80	80		
Supply cable terminals	mm2	35	35	35	35	35	35	NA	NA	35	35	35	35		
Wiring diagram															
Cabinet size		2							2						



### 1.6 Control Circuit Connections

#### 1.6.1 Control Circuit Wiring

Use a dedicated, earthed metal conduit for both the control signal cable and the security circuit cables, sharing the same conduit if practicable.

Use screened cable for all control and security circuit connections to minimise risk of electrical interference. The screen should be grounded at the VAPANET end only. See detail on page 9.

#### 1.6.2 On/Off Control

LExxLC models can be operated by a single step humidistat which has Volt-free contacts – UCP3 not fitted.

**Note:** See 1.6.4 Control Signal Selection below.

#### 1.6.3 Proportional Control

The VAPANET Electrode Boiler (LExxLC) models can all be operated by either a potentiometric signal or by one of the following standard proprietary DC analogue signals.

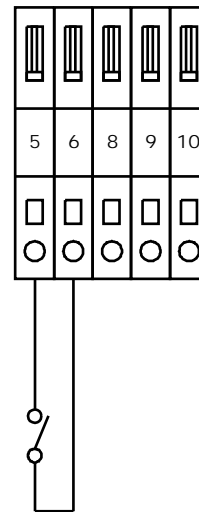
Input signal:

Standard	On/Off
1	0-5 V dc
2	0-10 V dc
3	2-10 V dc
4	1-18 V dc
5	0-20 V dc
6	4-20 mA
7	Pot

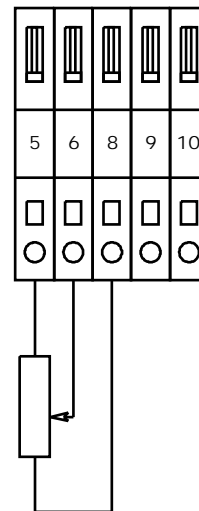
Response:

20 -100%

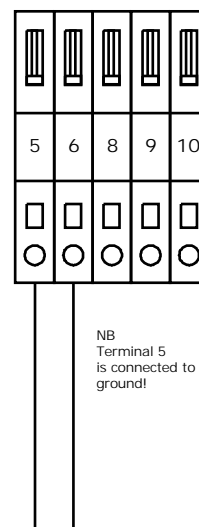
**NB.** The control signal is connected to ground at the PCB – if the controller output is referenced to ground, then the “leg” which is ground must be the one linked to terminal 5.



Hygrostat with Volt Free contacts  
Max resistance of external connection 100 Ohms.



Potentiometric Control  
Min. 135 Ohms  
Max 10k Ohms



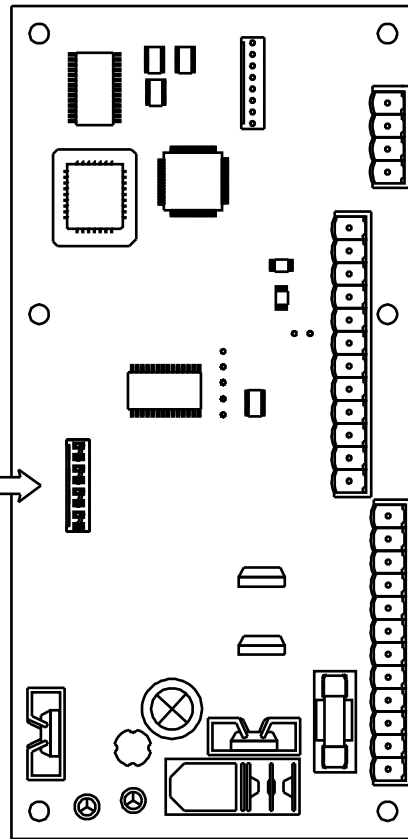
NB Terminal 5 is connected to ground!  
- +  
Proprietary DC Analogue Signal.

**1.6.4 Control Signal Selection**

Selection of the control signals is done by resistors fitted to UCP3

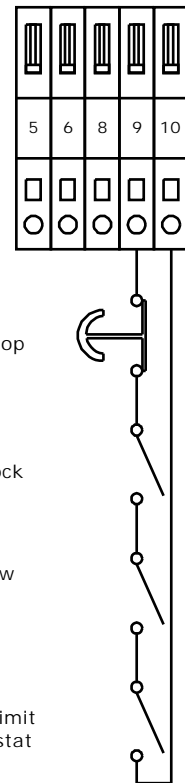
**NB** As standard (unless stated at time of order) "On/Off" will be set as standard.

Resistive Input #1  
 UCP3 (Resistive Input #2)  
 UCP2 (Resistive Input #3)  
 UCP1 (Resistive Input #4)



**1.6.5 Security Circuit / E.P.O. Shutdown**

As standard units are shipped such that terminals 9 & 10 are provided for connection of an E.P.O. (Emergency Power Off) switch or fire shutdown facility. Other control interlocks, such as high limit humidistat, airflow switch and/or fan interlock and time switches etc. should also be connected here.



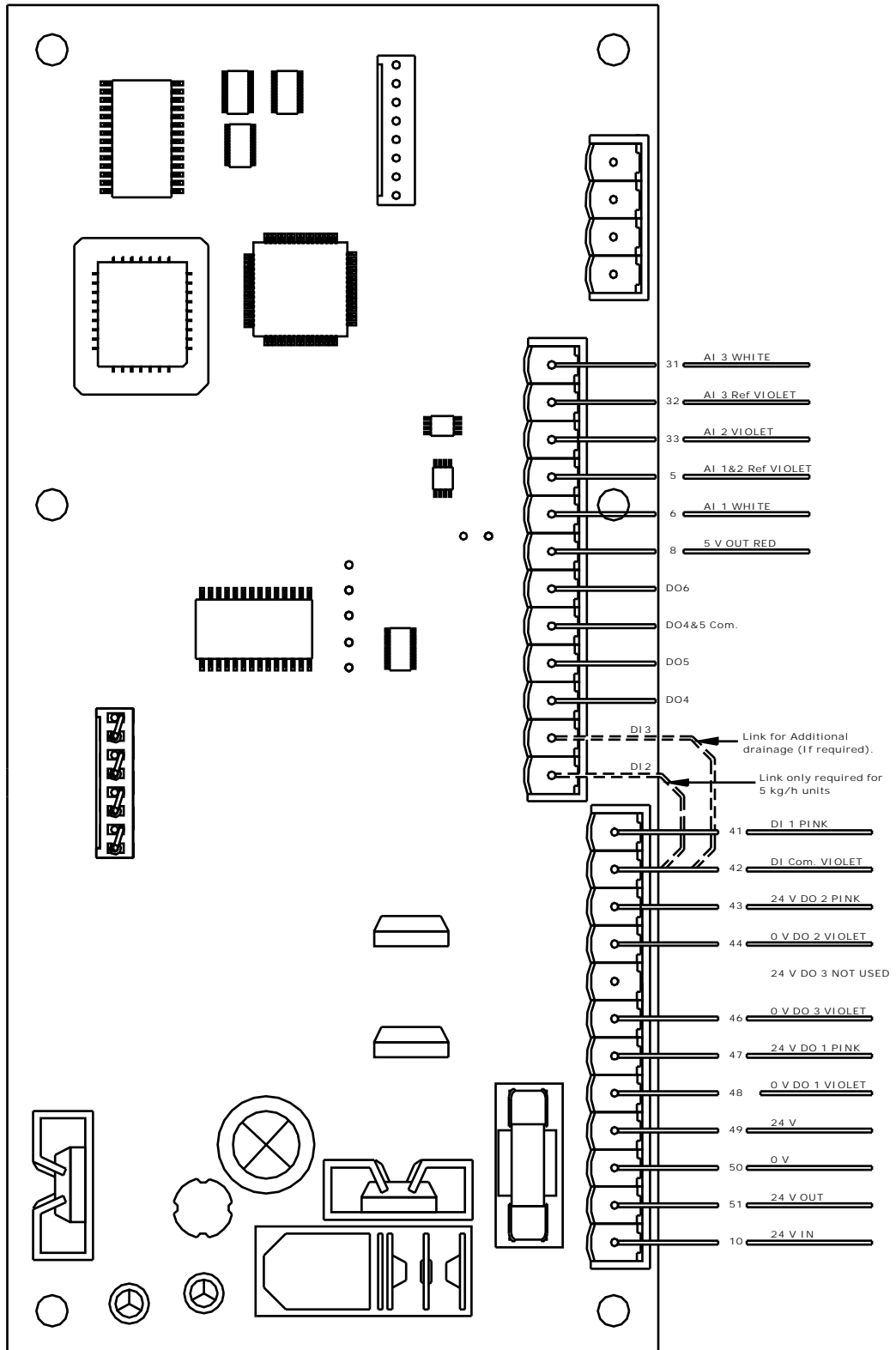
**Use of the 24V supply of the VAPANET unit to power other items of equipment will invalidate the Vapac warranty.**

**1.6.7 Drain operation**

As standard the unit is set for "Economy mode", which has a reduced automatic drain rate, which will reduce the amount of hot water (and therefore energy) which is expelled to drain. If the supply water is very conductive, or if the unit experiences operational difficulties it may be necessary to introduce additional drain cycles – this can be achieved by adding a link from DI 3 to DI (Com.) as shown. Please note there

may already be a factory fitted link DI 2 to DI (Com.) - in which case to avoid connecting three wires into one PCB connector terminal the link should be made between DI 3 & DI 2 instead.

**Under no circumstances should the link from DI 2 to DI (Com.) be made (or removed) other than by the manufacturer, as this could cause the unit to exceed its electrical ratings.**



## 2.0 Start-Up / Operation

### 2.0.1 Start-up check list

- a) **Water supply and Drain Connections:**  
These should be connected as indicated under Plumbing and in accordance with the relevant local regulations. An isolation valve should be adjacent to the unit. The connecting metal plumbing must be grounded close to the unit.
- b) **Steam Line:** This must be connected according to the installation instructions with adequate slope and support.
- c) **Power supply:** Wiring to the Vapanet unit should be by a qualified electrician and comply with the relevant regulations using appropriately sized cable and cable glands, with disconnect and fuses to suit the maximum fuse rating of the unit at the supply Voltage. The disconnect/fuses should be adjacent to the unit or within easy reach and readily accessible.
- d) **Control Connections:** Ensure the control signal and security circuit are correctly connected according to the relevant instructions/diagrams.
- e) **VAPANET 24v Control Circuit Transformer:** The standard 24V transformer used in the units has primary winding for 200V, 220/240V, 380V, 415V, & 440v 50/60Hz connection derived from the local electrical supply.  
Note: 60Hz connection must be specified with order as 230V 60Hz pump is required.
- f) The maximum output & kW rating of the unit is determined by a Current Set Plug. It is therefore possible to down rate units to any output, down to approximately 50% of the full rated output. (Contact Vapac for further details)
- g) Unit Configuration Plug (U.C.P.) sets the maximum current level for the unit. It is fitted directly onto the control P.C.B.

### 2.0.2 Start-Up Instructions

#### First check:

- a) **That the transformer connection matches supply Voltage.**
- b) **That the security circuit is closed for unit operation.**

Close the electrical access panel.

Turn on the water supply to the unit.

Close disconnect/circuit breaker feeding supply to the unit.

Close the On/Off switch.

### 2.0.3 Commissioning/Start-Up

Once the Set-Up procedure has been completed, the unit is available to operate according to the requirements of the control signal.

When starting with an empty cylinder, the VAPANET programme switches in the contactor and feeds water in until the water reaches the electrodes, and current starts to flow. Thereafter the VAPANET system will continuously monitor and control the conductivity by adjusting the amount of water drained and fed into the cylinder.

With no demand the LE unit's user LED's will be off. When the demand increases and the unit is switched

on the user LED's will flash green/amber at a rate depending on the demand input and the actual current drawn. The actual run current is monitored and until the actual current has two feeds above 95 % the LED will flash green/amber when the current is above 95% for two consecutive feeds the LED's will flash red.

### 2.0.4 Features of VAPANET Electrode Boiler Unit

The VAPANET system of control is designed to adjust the function to keep the unit operating in the face of changing water quality in the cylinder and changing electrode condition even if, in an adverse operational circumstance, this results in some reduction in output while the situation exists.

#### Foaming protection

In particular, the VAPANET is designed to prevent the onset of foaming and to introduce corrective drainage to keep the unit working.

#### Automatic switch-off

The VAPANET PCB will stop operating in response to extreme fault conditions identified as:

Drain Fault STOP (no drain function)

Feed Fault STOP (water not reaching cylinder)

In each case, the display will show the STOP condition and a Help Message, the User LED's on the fascia will indicate the condition see table on page 20.

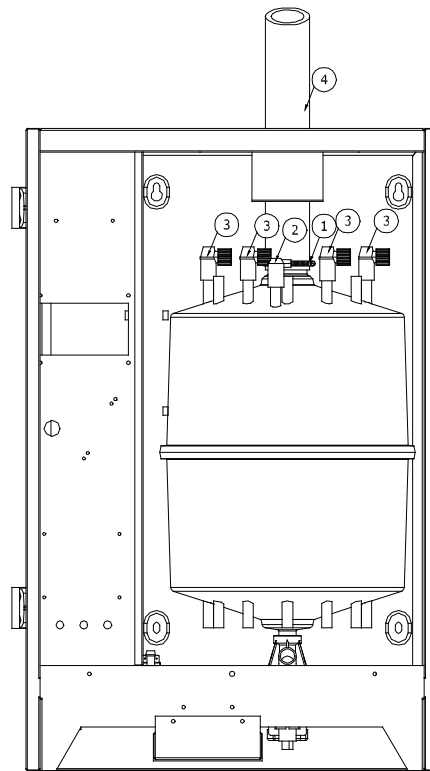
The STOP condition of a VAPANET PCB will be cleared by switching the unit off and on. **THIS ACTION SHOULD ONLY BE TAKEN ONCE THE CAUSE OF THE PROBLEM HAS BEEN ASCERTAINED AND RECTIFIED.**

**2.1 Service Advice**

The water hardness and the humidity demand at site will determine the effective life of a steam cylinder. Units located in areas with naturally soft waters will experience the longer cylinder life, possibly upwards of 12 months in calendar terms. With hard waters, a more frequent cylinder exchange must be expected and cylinder exchange 2 or 3 times a year can be the average situation. The normal scaling up of the Vapac steam cylinder is outside the Vapac warranty.

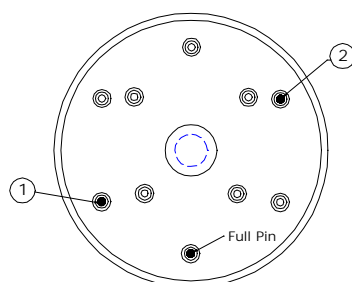
**2.1.1 Procedure for Cylinder Exchange.**

1. With the power connected to the unit, manually drain the unit, by depressing (and holding) the Run/Off/Drain Switch to the lower momentary drain position.
2. Disconnect the Vapac from the incoming electrical supply by means of the external isolator (disconnect switch). This should be "locked off" to prevent accidental operation.
3. Unlock the access panel, and remove to gain access to the steam cylinder.
4. Carefully ease off (lever) the electrode caps (2 & 3). If the cylinder is to be replaced, care should be taken not to twist the electrode caps while removing the black power caps, as the electrodes can rotate in the cylinder bosses (if the plastic cylinder is hot) and lead to unbalanced electrical loads.
5. Loosen the hose clip (1) and disconnect the steam hose (4) from the top of the cylinder.
6. Using a twisting movement, lift the cylinder clear of its seating in the feed/drain manifold and carefully remove the used cylinder from the unit.
7. Inspect the feed/drain manifold to ensure this is clear of sediment – check that silicone hoses are clear, clean replace as required.
8. The drain pump can be removed for inspection and cleaning by following the instructions below.
9. With the pump back in position, insert the cylinder into the feed/drain manifold, pushing it down firmly to ensure it is seated correctly.
10. Reconnect the steam hose.
11. Replace the electrode caps – ensure that they are replaced in the same sequence as when removed. With the cylinder full pin towards the front of the unit; electrode number 1 will be to the left of the white cylinder full electrode. Electrodes 2, 3, 4 etc will be sequentially connected clockwise around the cylinder (from number 1), when viewed from above. The cables carry colour-coded sleeves to indicate the phase and when connected correctly should follow the following sequence. Brown/Grey/Black/Brown/Grey/Black when viewed clockwise from the top. (NB The colour sequence for two electrode cylinders will be Brown/Black.
12. The connections to the cylinder should be routed in as close as possible to their original route.

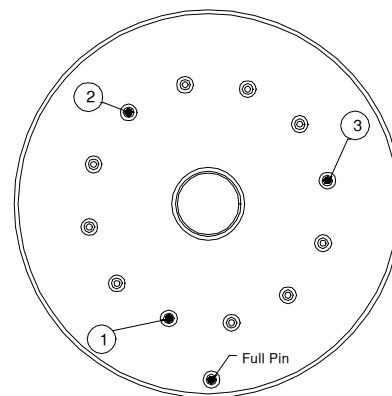


**Fig 1 Component Identification**

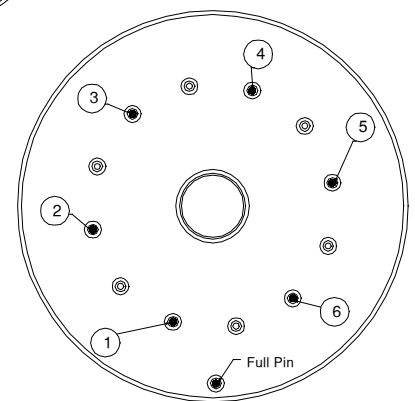
**2.1.2 Typical Cylinder / Electrode Layouts**



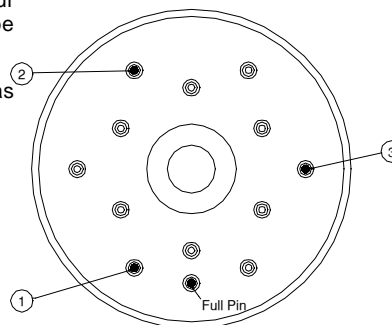
**Size 1 / 2 (2 electrode)**



**Size 4 (3 electrode)**



**Size 4 (6 electrode)**



**Size 3 (3 electrode)**

**See technical data for cylinder size fitted to your unit.**

**Other Maintenance:**

- Should only be carried out by a qualified electrician.
- The steam cylinder should be drained prior to carrying out any maintenance in the steam section – This must be done prior to isolating the electrical supply, i.e. before removing the front access panel.
- The unit should be isolated from the electrical supply before any cover or access panel is removed.

**2.2 Service and Maintenance**

As the operation of the Vapac is entirely automatic, it normally requires no attention on a day-to-day basis. General cleaning and maintenance of the component parts of the Vapac are recommended at intervals of about one year, but this is largely dependent upon the frequency of its use and the quality of the water supply. Where the Vapac is part of an air-conditioning system being serviced regularly, the Vapac should be inspected at the same time.

**2.2.1 Feed Valve with Strainer**

The nylon bodied solenoid valve incorporates a small nylon strainer which is a push fit in the 3/4" inlet of the valve. With a new plumbing installation, residual loose solid material in the pipework could partially block the strainer after start-up. If for this or any other reason a restriction of the water flow is suspected (outside of supply pressure considerations), it would be possible to clean the strainer as follows:-

Turn off the water supply to the Unit.

Undo the nylon nut connecting the flexible connection to the valve inlet.

The strainer can be removed using 'long-nosed' pliers to grip the centre flange provided on the strainer for this purpose.

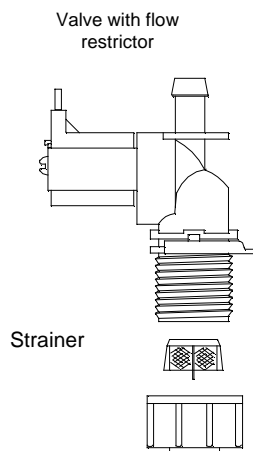
Withdraw the strainer.

Wash and replace it.

Reconnect and turn on water supply.

Reconnect electrical supply to allow unit to operate.

*Note: Always replace the strainer after cleaning as it is required to prevent material lodging in the valve seat or blocking the small flow control restrictor which is fitted in the valve.*



3/4 Nylon nut with washer as part of flexible connector

**2.2.2 Drain Pump**

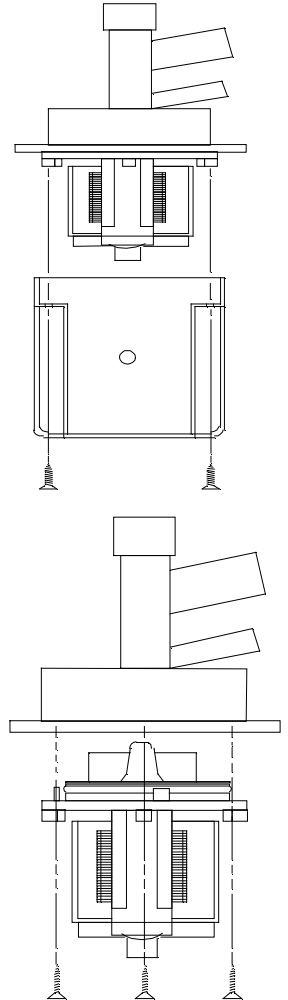
The pump is a sealed unit and should not be dismantled. Instructions for removal / replacement are as follows:

1) Place a bucket below the pump, to catch any water remaining in the housing or pipework.

2) Remove the two screws, holding the pump cover, & lift it clear.

3) Undo the three screws, holding the pump body to the feed & drain manifold, and remove it - any water trapped in the pump will be released at this point.

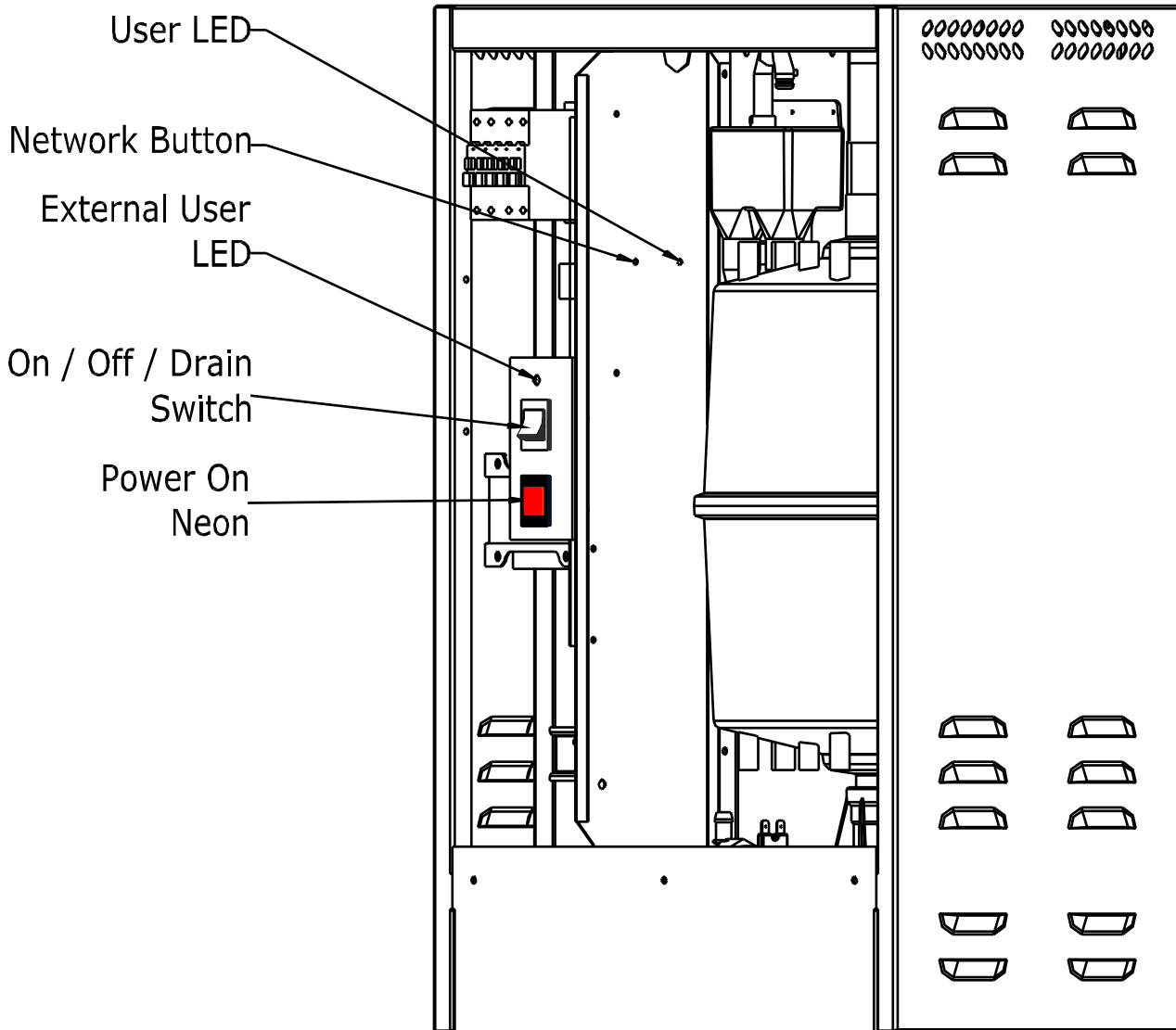
4) Fit the replacement pump by following the above steps in reverse order, ensuring that the O-ring surrounding the impeller housing is correctly seated, and that it mates correctly with the feed / drain manifold.

**Steam and Condensate Hoses**

The hoses used with and in the Vapac should be inspected at the normal service visits as part of normal maintenance. At the first signs of deterioration, a hose should be removed and replaced.

### 3.0 Location of Indicators and Controls

#### 3.1 Positioning of Indicators and Controls on Vapac® Vapanet® LELC Units.



## 3.2 Initial Set-up

### User LEDs

During the initialisation process the User LEDs can be in one of the following states

User LED State		Description
1	RED Flashing 2 second period	Unit initialising. If remains in this state, then unit does not a valid UCP1 fitted.

**Prior to the start of the initialisation process, the LEDs will flash Green, Red, Amber repeatedly for 10 seconds to check that the LEDs are operating correctly.**

#### Remedy:

- 1 Check that UCP1 is fitted to plug fitted to CR4 pins 7 & 8 see page 12.

### 3.3 Normal Run / Standby / Start-up – No User Intervention Required

User LEDs being off, RED or RED Flashing refer to following table.

User LEDs		Description																											
1	OFF	Unit in shutdown.																											
2	OFF	Unit in standby																											
3	Green Amber Flashing Variable	Unit in Startup.																											
	RED Flashing Variable Period or ON	Unit Online. The variable period is determined by the demand signal.																											
		<table border="0"> <thead> <tr> <th>Demand</th> <th>LED ON RED</th> <th>LED OFF</th> </tr> </thead> <tbody> <tr> <td>&lt;12.5%</td> <td>0.5 seconds</td> <td>3.5 seconds</td> </tr> <tr> <td>&lt;25%</td> <td>1.0 seconds</td> <td>3.0 seconds</td> </tr> <tr> <td>&lt;37.5%</td> <td>1.5 seconds</td> <td>2.5 seconds</td> </tr> <tr> <td>&lt;50%</td> <td>2.0 seconds</td> <td>2.0 seconds</td> </tr> <tr> <td>&lt;62.5%</td> <td>2.5 seconds</td> <td>1.5 seconds</td> </tr> <tr> <td>&lt;75%</td> <td>3.0 seconds</td> <td>1.0 seconds</td> </tr> <tr> <td>&lt;87.5%</td> <td>3.5 seconds</td> <td>0.5 seconds</td> </tr> <tr> <td>&gt;=87.5%</td> <td></td> <td>ON RED Continually</td> </tr> </tbody> </table>	Demand	LED ON RED	LED OFF	<12.5%	0.5 seconds	3.5 seconds	<25%	1.0 seconds	3.0 seconds	<37.5%	1.5 seconds	2.5 seconds	<50%	2.0 seconds	2.0 seconds	<62.5%	2.5 seconds	1.5 seconds	<75%	3.0 seconds	1.0 seconds	<87.5%	3.5 seconds	0.5 seconds	>=87.5%		ON RED Continually
Demand	LED ON RED	LED OFF																											
<12.5%	0.5 seconds	3.5 seconds																											
<25%	1.0 seconds	3.0 seconds																											
<37.5%	1.5 seconds	2.5 seconds																											
<50%	2.0 seconds	2.0 seconds																											
<62.5%	2.5 seconds	1.5 seconds																											
<75%	3.0 seconds	1.0 seconds																											
<87.5%	3.5 seconds	0.5 seconds																											
>=87.5%		ON RED Continually																											

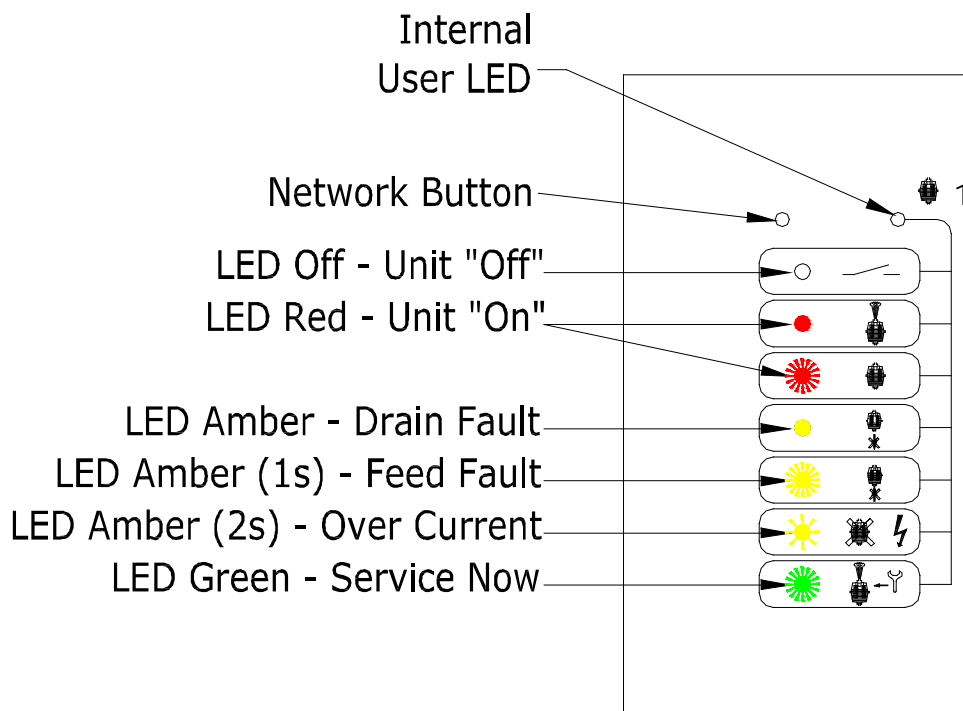
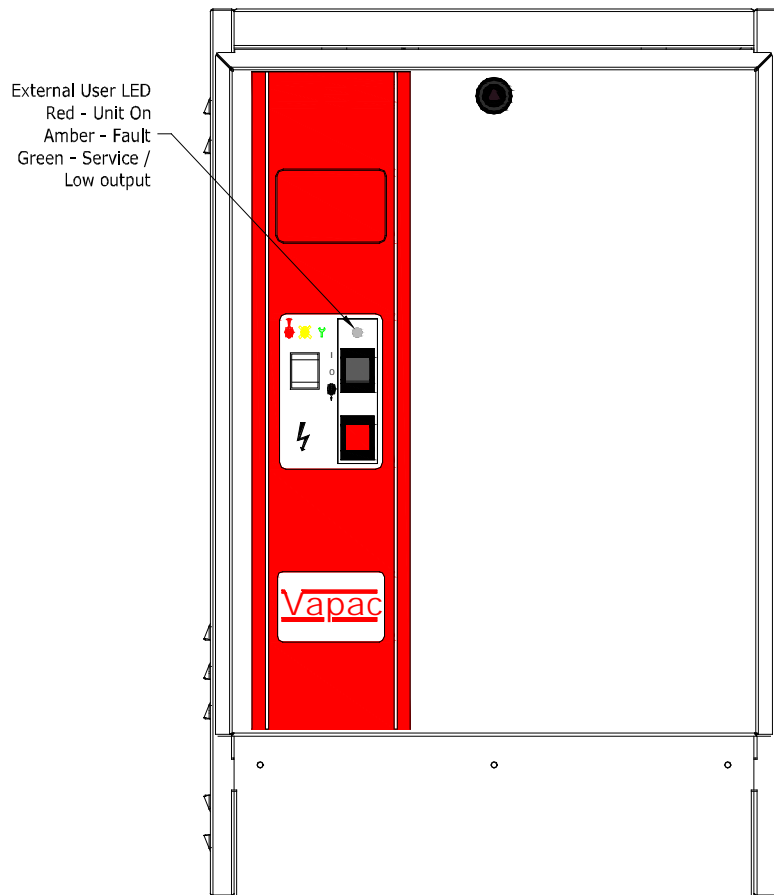
The above are purely indications of the current state of the unit and require no action from the operator. When the state changes, the indication will automatically change.

### 3.4 Fault / Service Indications – Requiring Operator Intervention.

User LED 1 State		Description
1	AMBER	Drain Fault
2	AMBER Flashing 1 second period	Feed Fault
3	AMBER Flashing 2 second period	Over current Fault
4	AMBER/OFF/AMBER/OFF /GREEN/OFF	No Voltage input
5	Green	Service Now

- 1, 2 & 3     **Fault stop:** Once the problem has been cleared the fault can be re-set by the following procedure.  
Power the unit right off, using the local isolator (not the unit on/off switch), waiting ten seconds then re-applying power.
- 4            **No voltage input:** Check the wiring to CR6 and CR7 of the “level sense” daughter board (part number 1150633-3). If the line voltage can be measured here, check the wiring between CR1 pins 5 & 6, of the same daughter board and CR2 pins 1 & 3 of the main control PCB. If this is also correct then either the daughter board or the main control PCB is faulty. Once the fault has been cleared the LED indications will revert back to the cylinders “current state”.
- 5            Service the unit, by following the instructions on pages 15 & 16.

3.3 Facia Label symbols



#### 4.0 Trouble-shooting Check List

**Preliminary** - **Use manual drain option to check pump operation**

<b>Symptom</b>	<b>Check/Cause/Remedy</b>
Power-On Neon – Off	- Check main power is connected and switched on.
Symbol-LED – Off	- Check power supply fuses.
Display - Blank	
Power-On Neon – On	- Check if security circuit is open circuit
Symbol-LED – On	- Check 24V 3.15A fuse mounted on the Vapanet controller PCB 1150655
Display - Blank	

#### **Automatic STOP – Feed Fault indicated.**

<b>Possibilities</b>	<b>Checks</b>
Water is not connected	- Check water stop valve is open.
Water connected but not reaching cylinder	- Check internal Vapac hose connections for a leak.
Water in cylinder and overflowing	- Check internal hoses for kinks or obstructions.

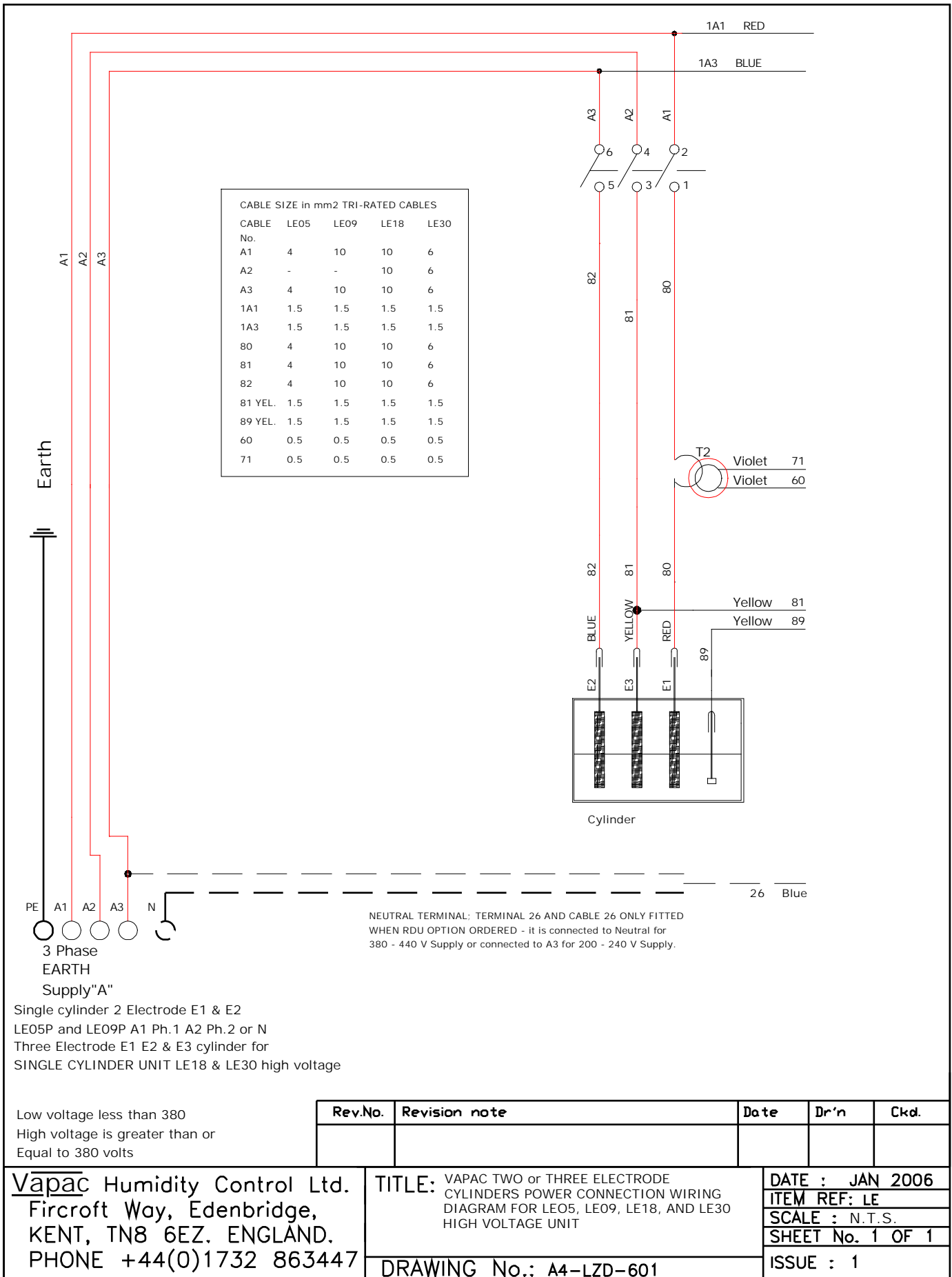
#### **Automatic Stop – Drain Fault indicated.**

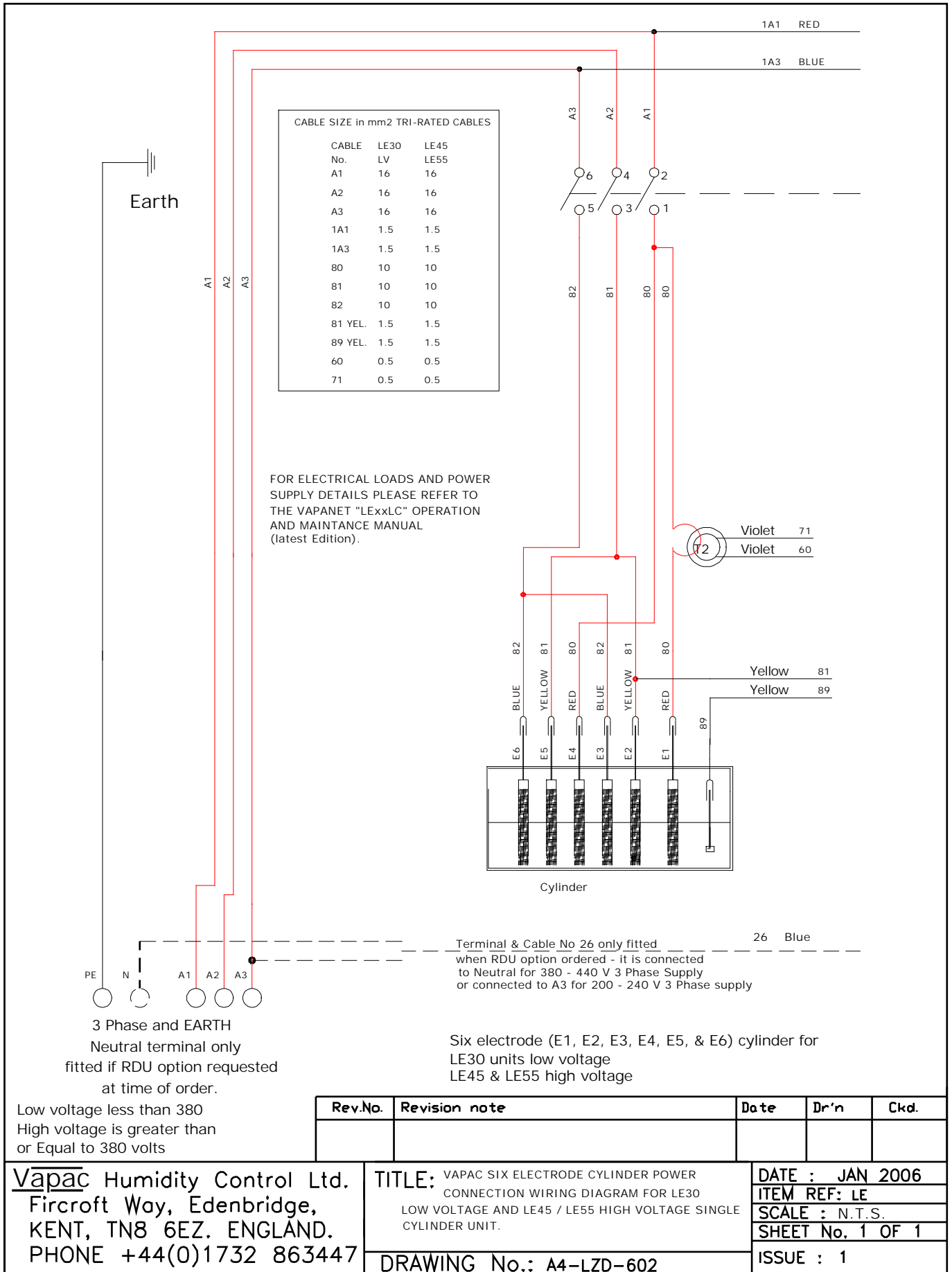
<b>Possibilities</b>	<b>Checks</b>
Drain pump function impaired	- If pump will not function, empty cylinder by disconnecting the water supply hose between the tundish and the cylinder (at the tundish fill-cup) and lowering it to drain the water into a bucket. Remove, dismantle and clean pump.
Cylinder O/Let Blocked	- Check & unblock.

#### **Unit On-Line but inadequate or no steam production.**

<b>Possibilities</b>	<b>Checks</b>
Contactors not made	- Contactor coil, Control PCB.
Cylinder scaled up.	- Cylinder Inspection (replace if necessary).



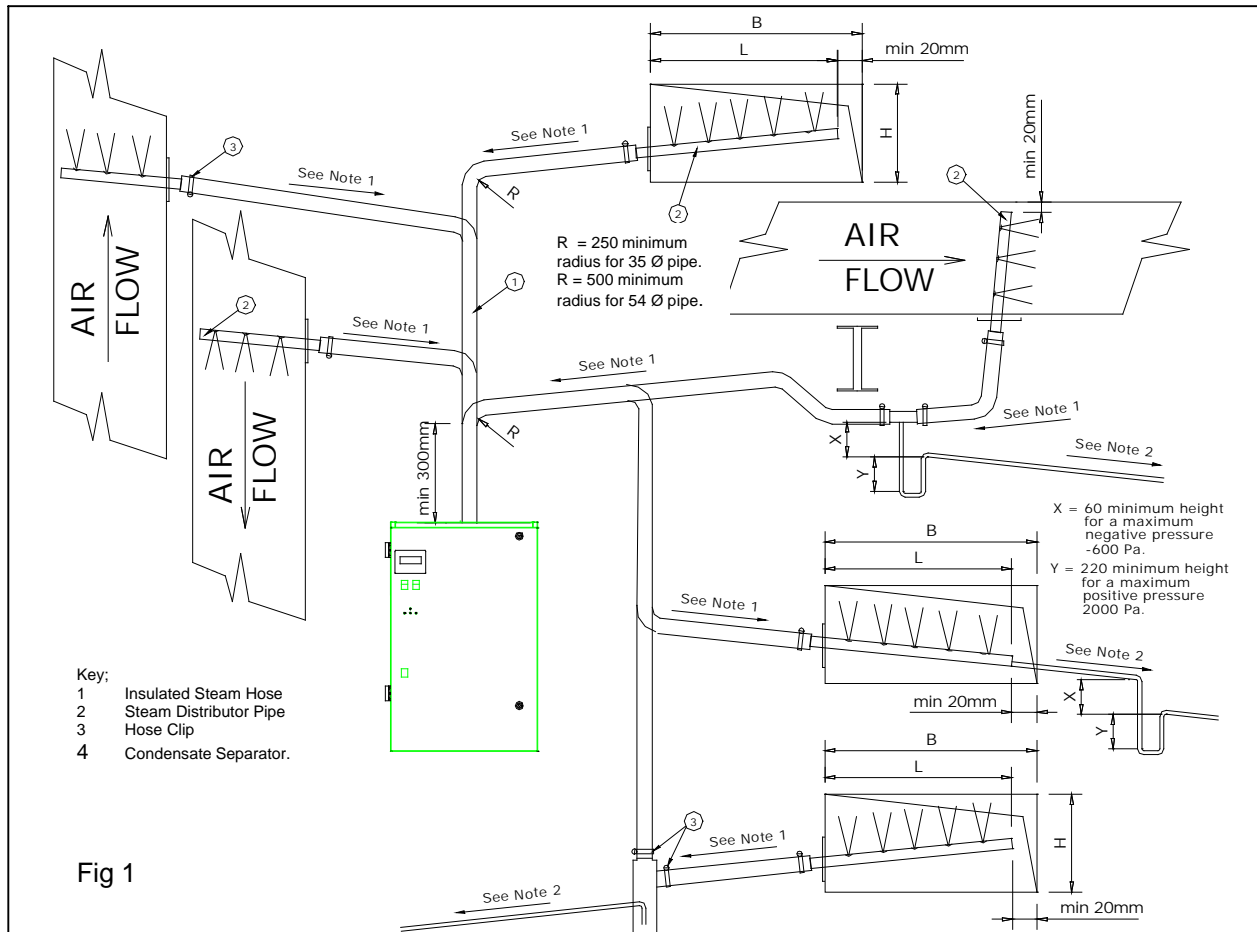




## Appendix 1.

### A Guide to Positioning Steam Pipes:

Vapac Humidity Control Ltd issues this as a guide only and accepts no responsibility for the positioning of any pipes in a system. This remains the responsibility of the Project Design Engineer.



- 1 Steam pipe to have a minimum slope from the horizontal of 7° or 12% to allow the condensate to drain back to the cylinder or trap. **NO HORIZONTAL RUNS. NO 90° ELBOWS.**
  - 2 Water condensate tube to slope at 10° or 18% from the horizontal for condensate to drain back to drain point.
  - 3 Steam pipes which are mounted horizontally must discharge vertically upward.
  - 4 Vertically mounted Steam pipes must discharge horizontally facing upstream airflow.
  - 5 If the total pressure within a duct air flow exceeds 2000 Pa and the static is below 2000 Pa then the probe may face horizontally at right angles to the air stream.
  - 6 Care should be taken to support steam hose sufficiently such that no kinks are formed which would flood with condensate causing the bore of the tube to become constricted, leading to excessive pressure in the steam lines.
- N.B Standard steam distribution pipes are manufactured such that any condensate is drained back towards the Vapac steam cylinder. Reverse slope pipes are available, and are fitted with a drain connector, to enable condensate to be taken away to a suitable drain.**

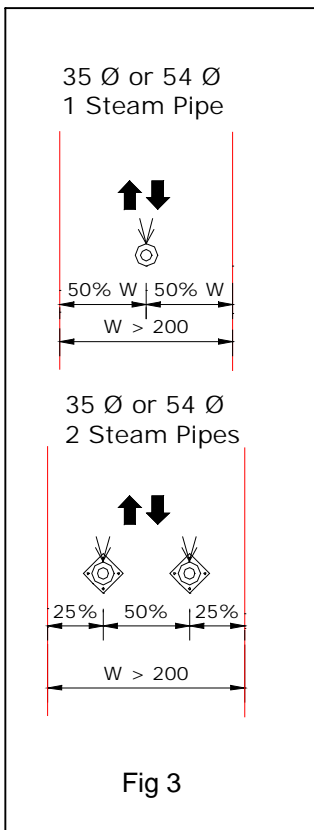
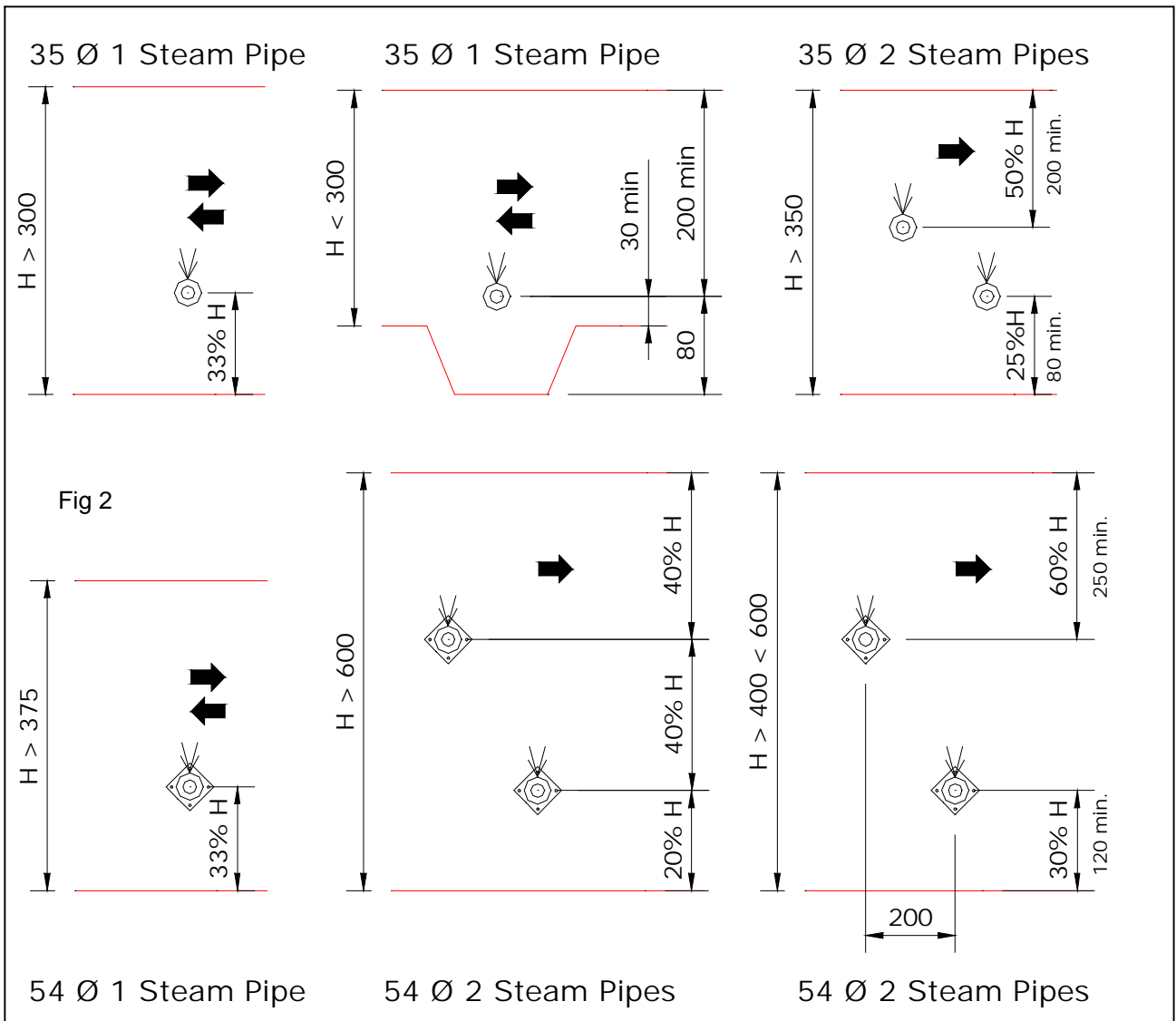


Fig 3

**Figure 1** shows the versatility of the steam pipe / steam hose steam delivery system. It also indicates where and how condensate traps / condensate separators should be used. If the steam pipe slopes such that the steam connection is lower than the far end of the pipe, this indicates that a reverse slope steam pipe is required. This is fitted with a drain point to allow condensate to be taken away to a convenient drain.

**Figure 2** shows recommendations on how to space one or more steam pipes in a horizontal duct.

**Figure 3** shows recommendations on how steam pipes should be spaced in a vertical duct

**Figure 4** shows mounting details for 35 and 54 Ø steam pipes

NB. The duct should be clear of obstructions, transformations and bends until the steam has been absorbed into the airflow. A guide to calculating this distance is available from Vapac – Part Number 0411047.

October 02

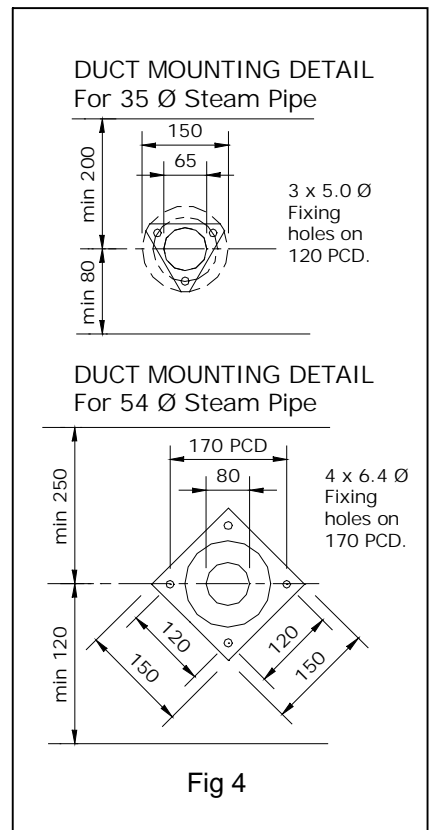
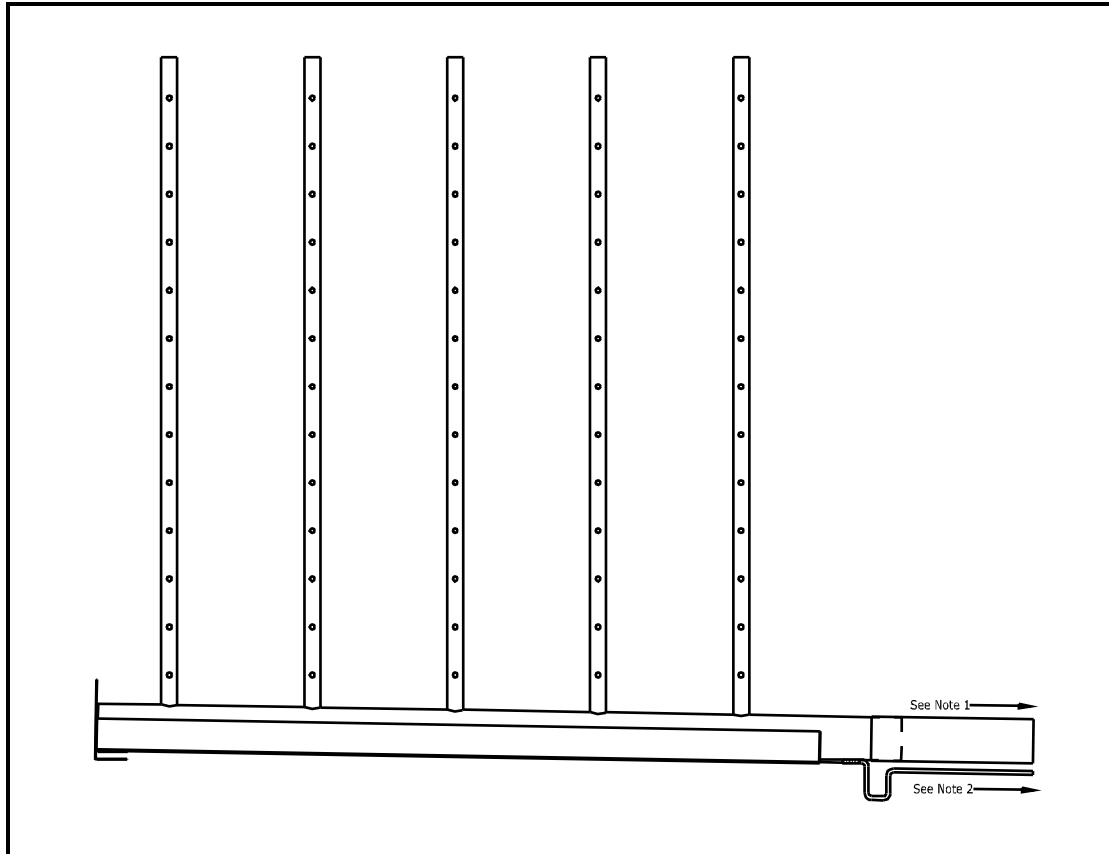


Fig 4

## Appendix 2

### A Guide to Positioning Multipipes:

Vapac Humidity Control Ltd issues this as a guide only and accepts no responsibility for the positioning of any pipes in a system. This remains the responsibility of the Project Design Engineer.



#### Notes:

- 1 Steam pipe to have a minimum slope from the horizontal of 7° or 12% to allow the condensate to drain back to the cylinder or trap. **NO HORIZONTAL RUNS. NO 90° ELBOWS.**
- 2 Water condensate tube to slope at 10° or 18% from the horizontal for condensate to drain back to drain point. A suitably sized trap will be required to prevent steam from escaping via the condensate drain connection.
- 3 Care should be taken to support steam hose sufficiently such that no kinks are formed which would flood with condensate causing the bore of the tube to become constricted, leading to excessive pressure in the steam lines.
- 4 The duct should be clear of obstructions, transformations and bends until the steam has been absorbed into the airflow. Vapac Humidity Control Ltd. suggests a figure of 1.5 times the estimated absorption distance stated on the "Multipipe" design sheet, which is supplied with the quotation.
- 5 Should it be necessary to slope the steam hose away from the Vapac Boiler, it will be necessary to fit a condensate separator to remove the condensate at the lowest point. This will need to be taken to a suitable drain.

October, 02

Made in England by:  
Vapac Humidity Control Ltd.

0410271  
24<sup>th</sup> October 2006

Vapac Humidity Control Ltd. reserve the right to change the design or specification of the equipment described in this manual without prior notice.

