

IPAC

edenaire

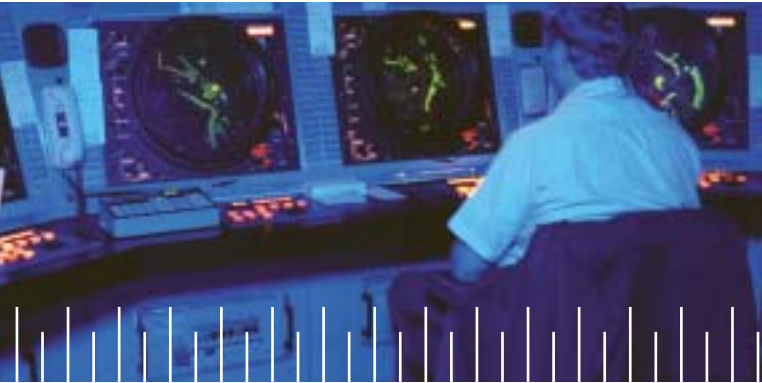

Invicta Precision Air Control
Floor Standing Range

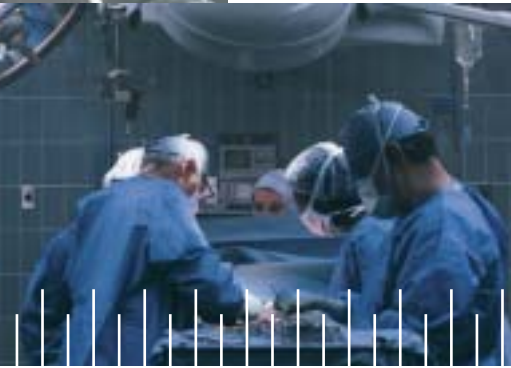
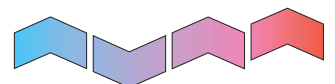



The Invicta Precision Air Control (IPAC) range of floor standing units has been developed to satisfy the exacting standards for full function air conditioned environments.

IPAC

Features

- **Modular Design.**
- **Energy Efficient.**
- **Open Architecture Control Protocol.**
- **Low Cost of Ownership.**
- **State of the Art Manufacturing.**
- **Designed for 24/7 Year Round Operation.**
- **BS EN ISO 9001.**

Applications

These units have been specifically designed and developed for a number of industries, including:

- **Commercial**
Computer Rooms, Server Rooms, Dealing Rooms and Showrooms.
- **Process Areas**
Control Rooms, Electronic Manufacturing, CD Manufacturing and Injection Moulding Facilities.
- **Environmental Control**
Archive Storage, Museums, Libraries, Art Galleries, Testing & Measurement Laboratories and Textile Laboratories.
- **Telecommunications**
Internet Farms and Switch Rooms.
- **Industrial**
Petrochemical, Manufacturing Areas and Airports.
- **Medical**
Clean Rooms and Medical & Pharmaceutical Facilities.



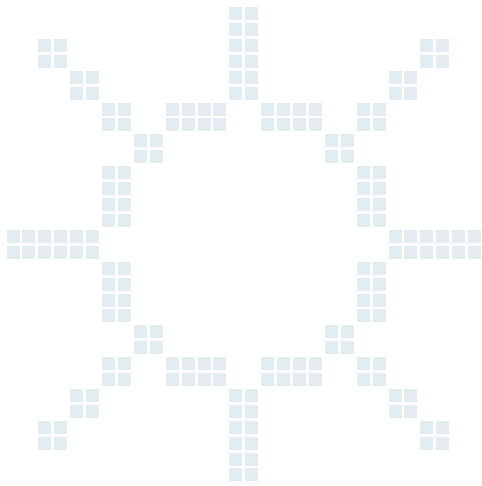

Duty Range

The IPAC range has been developed to provide a flexible duty range of units.

- Stand alone units currently range from a nominal 15 kW to 80 kW.
- Master/Slave combinations extend the range for larger applications.

Precision Air Control Equipment

The IPAC floor standing units are in their most basic form available in chilled water or DX cooling only configuration. These systems can either be mounted inside the conditioned space or mounted remotely, with the fan developing external pressure to transport the air to the conditioned space. Units can be manufactured with an upflow or downflow air pattern to enable optimum comfort levels.

Depending on the application, heating, dehumidification, humidification and air filtration can also be provided.

As well as the standard unit configurations, a variety of options can be factory or site-fitted to customise units to the system requirements. This provides the designer, installer and customer with a system that can precisely match the requirements.

Controller

The Eaton-Williams controller is a purpose designed LonWorks™ microprocessor, which fully complies with EEC directives for electromagnetic compatibility (EMC).

The controller is powered from a 9 V and 24 V 50 Hz power supply, these are provided via a transformer mounted within the electrical chassis.

All outputs are protected by shrouded fuses.

The Controller Hardware Consists of:

- Display and push-button assembly.
- Microprocessor controller assembly.

The Controller Includes the Following Features as Standard:

- Temperature and humidity set point adjustment.
- Dead band adjustment.
- Proportional band adjustment.
- Alarm band adjustment (individually for temperature and humidity).
- Fault and service alarm volt-free contacts.
- Winter low pressure switch delay timer adjustment.
- Start delay timers.
- Historical alarm logging.
- Lon network communications.
- Stand-alone or Master/Slave.
- Run/Standby and duty rotations.

Temperature Control

IPAC units are designed to operate at room temperatures from 18 °C to 30 °C as standard and with factory added options can operate outside this range. Temperature can be precisely controlled, with cooling provided by a chilled water system or a DX unit with an external air-cooled condenser (option of water-cooled condenser available). Where heating is required, the alternatives of electric or low pressure hot water heating are available.

Humidity Control

Where humidity control is required, the IPAC unit is factory fitted with the facility whereby the cooling coil is operated below the dew point of the conditioned air to provide dehumidification. To ensure optimum temperature control in conjunction with dehumidification the options of hot gas or electric reheat are available.

The unit can also be fitted with a proportional output humidifier to provide clean sterile steam. The humidifier responds to a changing demand using the water level (WL) system of modulation. Output is varied by increasing or decreasing the level of water in the cylinder. A decrease in water volume causes less electrical energy (measured in amperes) to pass between the electrodes, transforming less water into steam. An increase in water volume, logically, has the opposite effect. WL can modulate down to 20 % of full output.

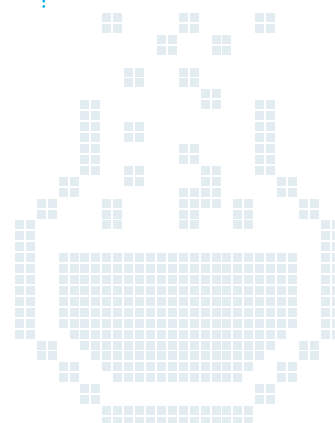
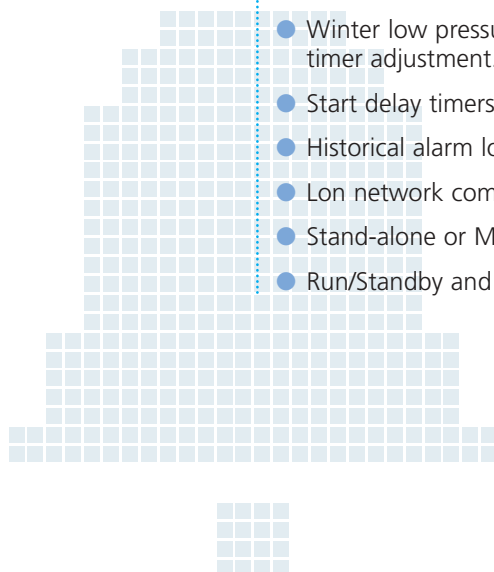

Air Quality and Distribution

The IPAC range is fitted with EU4 filters to provide air quality control, with the option of EU6, EU7 (higher filtration levels are available, but will be located in an external filter section). The units are fitted with a fan/motor combination capable of supplying the design airflow against the external resistance of a typical air distribution system as well as providing a quantity of fresh air into the conditioned space.

All Year Round Operation

IPAC units are designed to operate 24 hours a day, all year round, in any mode (i.e. cooling/heating/dehumidification/humidification) and come complete with condenser fan speed and pressure control to avoid problems associated with over condensing during winter cooling.

Ease of Maintenance

In rugged environments in which air conditioning units are installed it is essential to carry out regular maintenance for optimum performance. As well as using top quality components, ease of maintenance has been designed into these systems. The controller automatically indicates when maintenance is required on individual components and all servicing can be carried out through the front door(s) of the unit.

Selecting a System

The overall building services design will define the type of cooling system required. As standard, the IPAC range is available in three basic systems:

- Direct expansion cooling with air-cooled condenser.
- Direct expansion cooling with water-cooled condenser.
- Chilled water cooling.

Cooling, Cooling with Heating or Full Air Conditioning

Different applications require different modes of control and the IPAC range is available in three basic configurations:

- Cooling only (cooling unit).
- Cooling with heating (temperature unit).
- Cooling with heating and humidification/dehumidification (full A/C unit).

Air-Cooled Condensers

A matched range of air cooled condensers are available for operation in ambient temperatures up to 35 °C. However, for higher ambients, uprated air-cooled condenser(s) can be supplied.

Nominal Direct Expansion and Chilled Water Unit Ratings

IPAC Model		15	22	30	32	40	45	55	60	70	80
Total Cooling (DX)	kW	16.0	22.0	30.0	32.0	40.7	46.0	56.0	60.0	70.6	81.4
Gross Sensible Cooling (DX) *	kW	14.8	20.9	28.1	29.6	37.4	42.9	52.2	56.2	65.5	74.8
Sensible Heat Ratio (DX)		0.92	0.95	0.94	0.92	0.92	0.93	0.93	0.94	0.93	0.92
Total Cooling (C/W)	kW	24.0	33.8	42.5	48.0	59.5	66.5	83.5	85.0	102.0	119.0
Gross Sensible Cooling (C/W) **	kW	18.7	26.0	33.6	37.4	47.0	52.5	66.0	67.2	80.6	94.0
Sensible Heat Ratio (C/W)		78	77	79	78	79	79	79	79	79	79
Airflow	m ³ /s	1.25	1.70	2.25	2.50	3.20	3.50	4.65	4.50	5.45	6.40
Airflow	m ³ /h	4500	6120	8100	9000	11520	12600	16020	16200	19620	23040
Standard External	Pa	70	70	70	70	70	70	70	70	70	70
Maximum External (Clean Filters) †	Pa	400	400	400	400	360	400	360	400	360	360
Electrical Heating	kW	5	10	10	5	15	10	15	10	15	15
Humidification	kg/h	5	9	9	5	9	9	9	9	9	9
Filtration		G4	G4	G4	G4	G4	G4	G4	G4	G4	G4
Noise Level ‡	dB(A)	55	56	61	58	67.8	63	67	64	70	70
Condenser (For DX System)		ICV1-18P	ICV1-40P	ICV2-40P	ICV1-18P ICV1-18P	ICV2-70P	ICV2-40P ICV1-18P	ICV2-70P ICV1-18P	ICV2-40P ICV2-40P	ICV2-70P ICV2-40P	ICV2-70P ICV2-70P
Outdoor Unit Noise Level §	dB(A)	58	58	59	59	59	59	59	59	59	59

* Unit ratings at 24 °C / 50 % RH Internal and 35 °C External. ** Unit rating at 24 °C / 50 % RH and chilled water 7 °C Flow / 12 °C Return.

† Maximum external pressure would be optional via a pulley / motor change (client to specify at time of order).

‡ Sound pressure level per cabinet at a distance of 3 m from the unit with floor return and ducted supply.

§ Sound pressure level per condenser at a distance of 3 m from the unit.

Airflow Configuration

The IPAC unit airflow can be configured in order to make site installation as easy as possible.

Upflow Units

- Bottom return air inlet, with top outlet air supply (standard).
- Front return air inlet, with top outlet air supply (factory fit option).
- Back return air inlet, with top outlet air supply (site-configurable).

Downflow Units

- Top return air inlet, with bottom outlet air supply (standard).
- Front return air inlet, with bottom outlet air supply (factory fit option).
- Back return air inlet, with bottom outlet air supply (site-configurable).

A variety of header boxes and base plinths can be supplied to suit the above units.

Upflow configurations

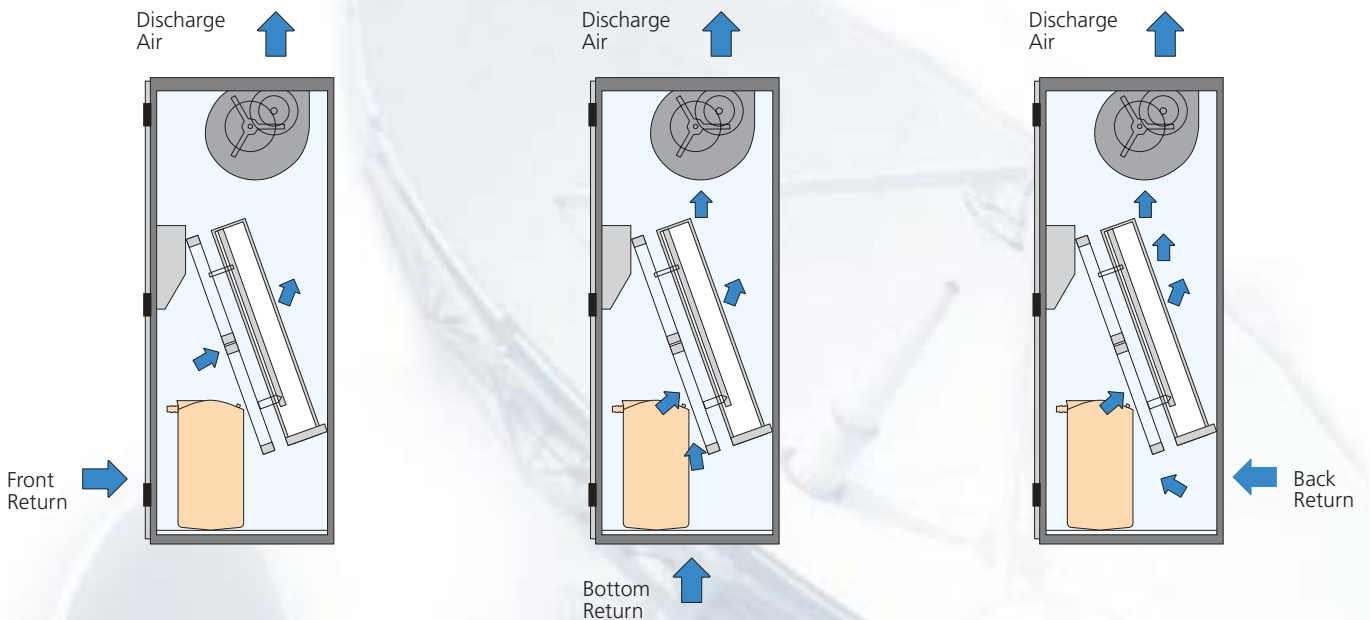

Downflow configurations

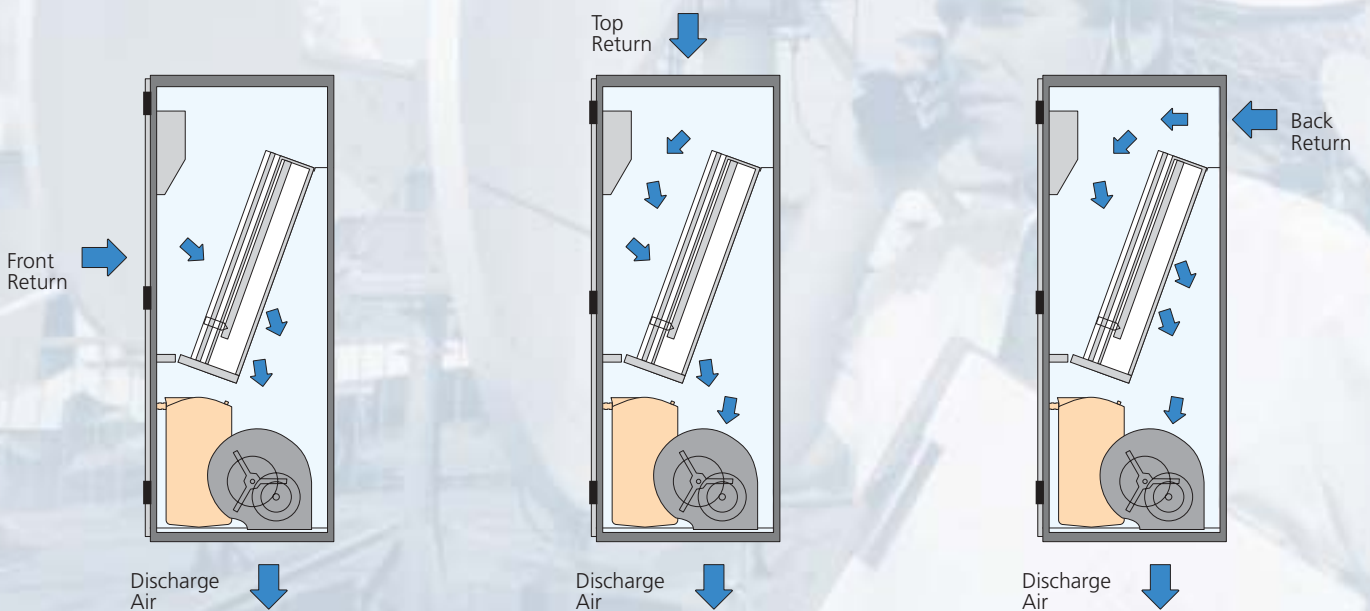

Technical Specifications

Pipework connection sizes

IPAC Model		15	22	30	32*	40	45*	55*	60*	70*	80*
Indoor Liquid Line Connection	inch	3/8	1/2	1/2	3/8 3/8	5/8	1/2 3/8	5/8 3/8	1/2 1/2	5/8 1/2	5/8 5/8
Outdoor Liquid Line Connection	inch	3/8	1/2	1/2	3/8 3/8	5/8	1/2 3/8	5/8 3/8	1/2 1/2	5/8 1/2	5/8 5/8
Indoor Discharge Line Connection	inch	1/2	3/4	3/4	1/2 1/2	7/8	3/4 1/2	7/8 1/2	3/4 3/4	7/8 3/4	7/8 7/8
Outdoor Discharge Line Connection	inch	3/4	7/8	7/8	3/4 3/4	7/8	7/8 3/4	7/8 3/4	7/8 3/4	7/8 7/8	7/8 7/8
C/W Connection Size	mm	28	35	35	28 28	42	35 28	42 28	35 35	42 35	42 42

All pipe connections brazed (standard) — options available. * Dual cabinet units have two sets of pipework connections.

Pipework line sizes guide

IPAC Model		15	22	30	32†	40	45†	55†	60†	70†	80†
Up to 10 m Pipe Run Length	Liquid inch	1/2	1/2	5/8	1/2 1/2	3/4	5/8 1/2	3/4 1/2	5/8 5/8	3/4 3/4	3/4 3/4
	Discharge inch	3/4	3/4	7/8	3/4 3/4	1 1/8	7/8 3/4	1 1/8 3/4	7/8 7/8	1 1/8 7/8	1 1/8 1 1/8
10 to 30 m Pipe Run Length	Liquid inch	5/8	5/8	3/4	5/8 5/8	3/4	3/4 5/8	3/4 5/8	3/4 3/4	3/4 3/4	3/4 3/4
	Discharge inch	7/8	7/8	1 1/8	7/8 7/8	1 1/8	1 1/8 7/8	1 1/8 7/8	1 1/8 1 1/8	1 1/8 1 1/8	1 1/8 1 1/8
30 to 50 m Pipe Run Length	Liquid Inch	5/8	5/8	3/4	5/8 5/8	7/8	3/4 5/8	7/8 5/8	3/4 3/4	7/8 3/4	7/8 7/8
	Discharge inch	7/8	1 1/8	1 1/8	7/8 7/8	1 3/8	1 1/8 7/8	1 3/8 7/8	1 1/8 1 1/8	1 3/8 1 1/8	1 3/8 1 3/8

All pipe connections brazed (standard) — options available. Pipework for sizes guide only, qualified personnel should specify pipework subject to site layout/conditions. † Dual cabinet units have two sets of interconnecting pipework.

General service connections

IPAC Model		15	22	30	32	40	45	55	60	70	80
Humidifier Water Feed ‡		15 mm Cu		15 mm Cu		15 mm Cu		15 mm Cu		15 mm Cu	
Condensate/Humidifier Drain Connection I/D Tube	mm	22	2 x 22	22	2 x 22	22	2 x 22	2 x 22	2 x 22	2 x 22	2 x 22
Fixing Down Bolts/Unit Ancillaries	mm	M6		M6		M6		M6		M6	
Power Supply	V / ph / Hz	400/3/50		400/3/50		400/3/50		400/3/50		400/3/50	
Indoor Unit Power Supply — Cable Details		5 core 3ph/N/E		5 core 3ph/N/E		5 core 3ph/N/E		5 core 3ph/N/E		5 core 3ph/N/E	
Outdoor Unit Interconnecting Cables		3 core L/N/E		3 core L/N/E		3 core L/N/E		3 core L/N/E		3 core L/N/E	

‡ Push-fit connection for copper pipe.

Range electrical details

IPAC Model		15	22	30	32‡	40	45‡	55‡	60‡	70‡	80‡
Fan Motor(s)	Power Rating kW	0.9	2.0	2.6	0.9 0.9	4.0	2.6 0.9	4.0 0.9	2.6 2.6	4.0 2.6	4.0 4.0
	FLC A/ph	2.7	5.7	6.2	2.7 2.7	8.3	6.2 2.7	8.3 2.7	6.2 6.2	8.3 6.2	8.3 8.3
Compressor(s)	Power Rating kW	4.1	6.4	6.8	4.1 4.1	10.4	6.8 4.1	10.4 4.1	6.8 6.8	10.6 6.8	10.6 10.6
	FLC A/ph	7.9	12.1	13.0	7.9 7.9	16.3	13.0 7.9	16.3 7.9	13.0 13.0	16.3 13.0	16.3 16.3
Electrical Heater(s)	Power Rating kW	5	10	10	5 —	15	10 —	15 —	10 —	15 —	15 —
	FLC A/ph	10.4	20.8	20.8	10.4 —	20.8	20.8 —	20.8 —	20.8 —	20.8 —	20.8 —
Internal Humidifier	Power Rating kW	4	6.8	6.8	4 —	6.8	6.8 —	6.8 —	6.8 —	6.8 —	6.8 —
	FLC A/ph	5.7	10.2	10.2	5.7 —	10.2	10.2 —	10.2 —	10.2 —	10.2 —	10.2 —
Condenser(s)	Power Rating kW	0.7	1.5	1.5	0.7 0.7	1.5	1.5 0.7	1.5 0.7	1.5 1.5	1.5 1.5	1.5 1.5
	FLC A/ph	3.2	6.4	6.4	3.2 3.2	6.4	6.4 3.2	6.4 3.2	6.4 6.4	6.4 6.4	6.6 6.6
Total — Cooling Unit (DX)	Max. Running Current A/ph	13.8	25.5	26.3	27.6	31.8	40.1	45.6	52.7	58.1	63.5
Total — Temp Unit (DX)	Max. Running Current A/ph	13.8	25.5	26.3	27.6	31.8	40.1	45.6	52.7	58.1	63.5
Total — Full A/C Unit (DX)	Max. Running Current A/ph	23.8	35.5	39.2	37.6	51.8	53.0	65.6	65.6	78.1	83.6
Total — Cooling Unit (C/W)	Max. Running Current A/ph	3.7	7.2	7.2	7.4	9.3	10.9	13.0	14.4	16.5	18.6
Total — Temp Unit (C/W)	Max. Running Current A/ph	12.7	26.2	26.2	16.4	29.3	29.9	33.0	33.4	36.5	38.6
Total — Full A/C Unit (C/W)	Max. Running Current A/ph	17.5	36.4	36.4	21.2	39.5	40.1	43.2	43.6	46.7	48.8

Full load currents (FLC) are at standard design conditions. ‡ For dual cabinet units add component electrical figures together where appropriate.

Technical Specifications

Internal unit dimensions and weights

IPAC Model		15	22	30	32	40	45	55	60	70	80
Unit Height (A)	mm	1950	1950	1950	1950	1950	1950	1950	1950	1950	1950
Unit Width (B)	mm	800	1300	1300	1600	1700	2100	2500	2600	3000	3400
Unit Depth	mm	800	800	800	800	800	800	800	800	800	800
Unit Weight	kg	270	380	402	520	472	652	722	782	852	916

Internal unit colour BS00A05 (nearest equivalent RAL 7035).

Unit configurations

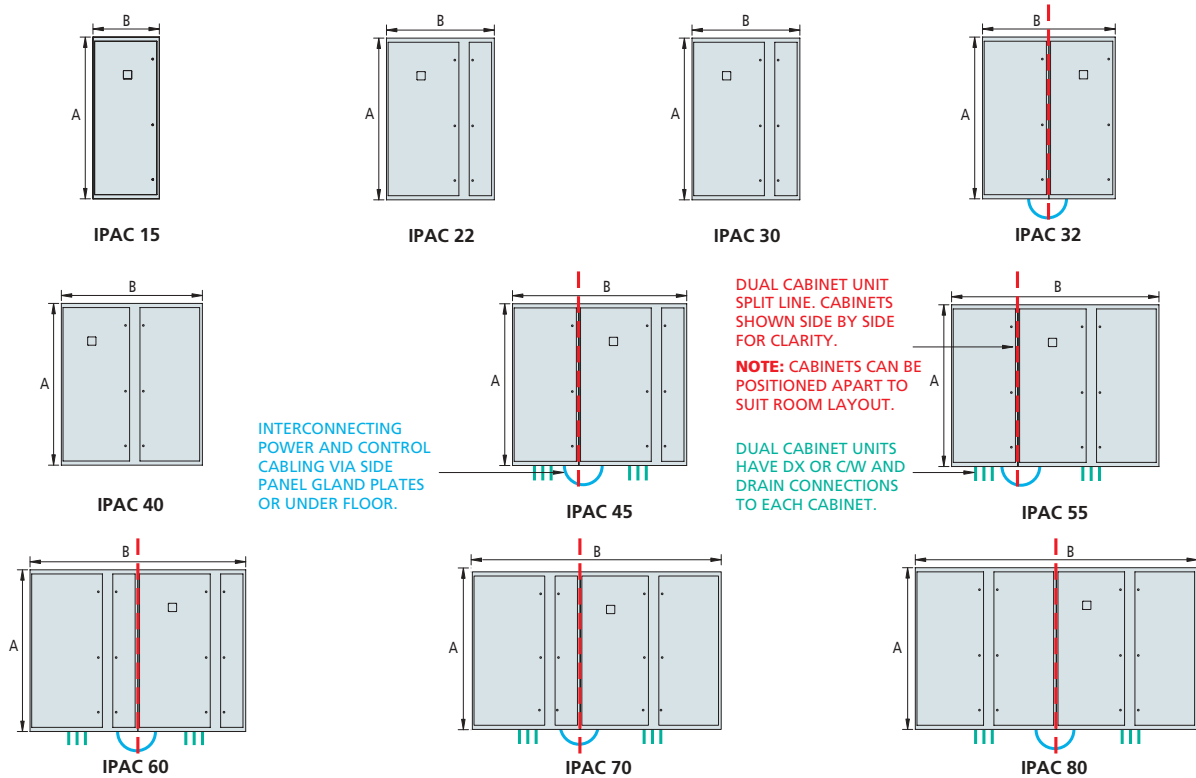

ICV condenser dimensions and weights

ICV Model		ICV1-18P	ICV1-40P	ICV2-40P	ICV2-70P
ICV Condenser Height (A)	mm	855	875	875	875
ICV Condenser Width (B)	mm	948	2023	2023	2023
ICV Condenser Depth (C)	mm	772	772	772	1000
ICV Condenser Weight	mm	47	50	54	66

Please note: the condensers can be used in both horizontal and vertical airflow modes. Condensers are fitted with isolator and pressure actuated fan speed controller as standard.

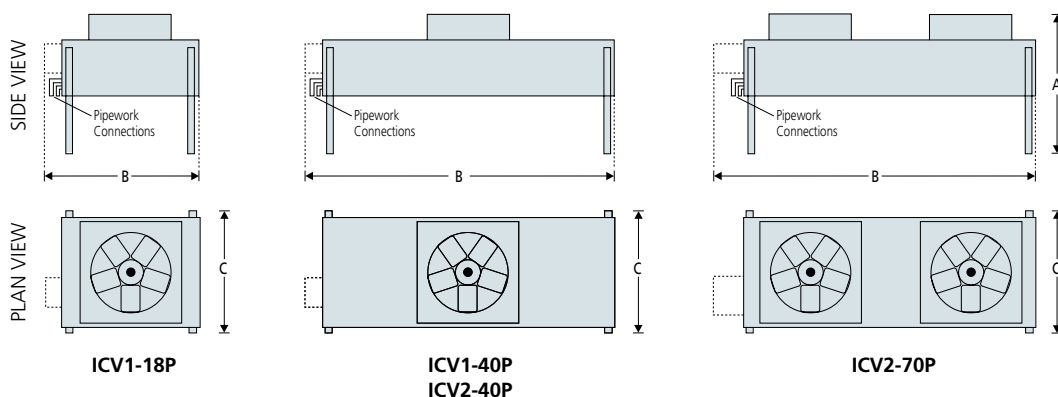

PRODUCT RANGES

Air-cooled & Water-cooled Liquid Chillers

Packaged Roof-Top Units

Full Range of Air Handling Units

Fan Coil Units

Package Telecommunications Units

Fresh Air Units

Condensing Units

Air Cooled Condensers

Low Temperature Cassettes

Cellar & Storage Low Temperature Cooling Units

Packaged In-Wall Units

Stand-alone Humidifiers

OEM Process Cooling Control Units

Custom Designed Packages



Eaton-Williams

Eaton-Williams Air Conditioning

Station Road, Edenbridge
Kent TN8 6EG, England
Telephone: +44 (0)1732 866055
Facsimile: +44 (0)1732 866653
www.eaton-williams.com

Part of the
CESgroup

We reserve the right to alter specifications without notice and products will sometimes be supplied with modifications which do not strictly comply with the descriptions and illustrations in this publication.