

WATERSIDE HORIZONTAL CEILING VOID FAN COIL UNITS

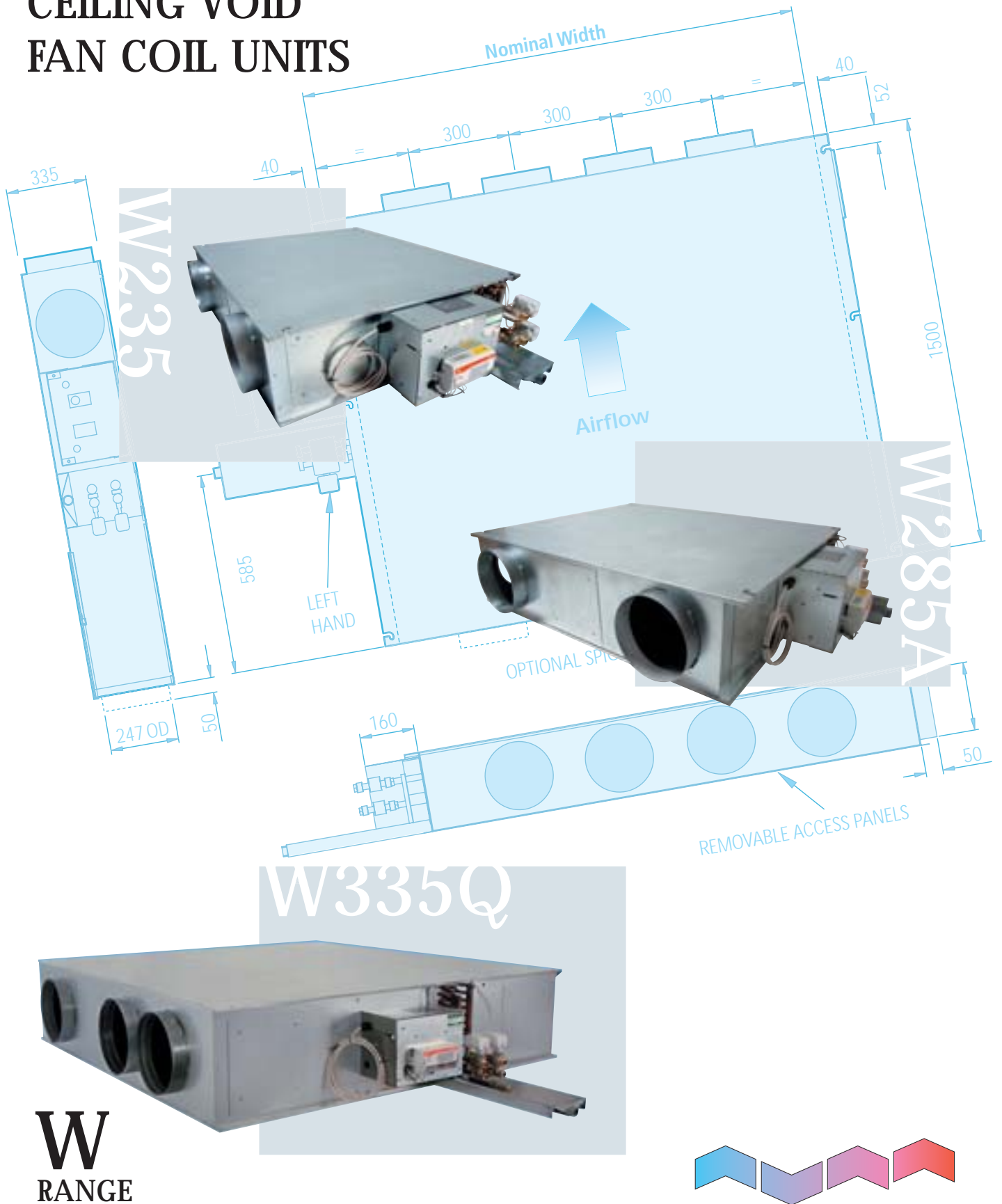

W
RANGE

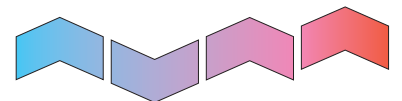

Moducel's latest range of fan coil units offer a choice of Waterside models and incorporate design features that deliver value added benefits for many diverse applications.

With over 40 years' experience as an industry leader in the design and manufacture of air handling plant for specialised HVAC applications, Moducel's products are used in many industrial and commercial environments from manufacturing, aerospace, hospitals, sports and leisure, supermarket chains and pharmaceutical applications to extremely demanding environments such as clean rooms in bio-chemical and semi-conductor industries.

Moducel's highly skilled teams in Stoke-on-Trent take pride in delivering effective solutions. Customers are assured of receiving expert advice for their air handling and fan coil technology projects, backed up with comprehensive service and maintenance packages if required.



Southfield School and Grange Technology College.



Canary Wharf.



University Academy Keighley.



The Met Office.



Radisson Hotels & Resorts.

PERFORMANCE SUMMARY

Cooling Performance

Air on/off at 23°C/16°C, water on/off at 6°C/12°C, external static pressure at 30 Pa

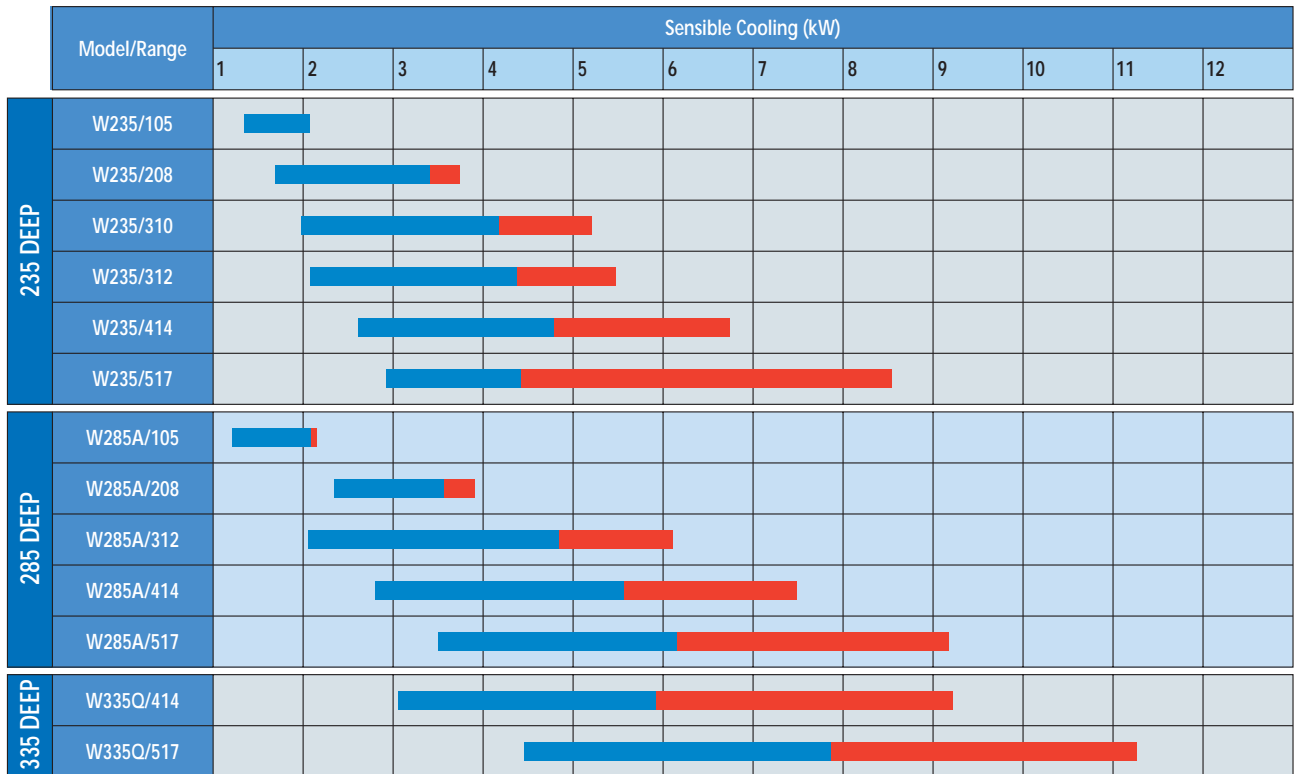

[Red bar] All selections in this region will be greater than NR35.

Airflow Rate Summary

Air on/off at 23°C/16°C, water on/off at 6°C/12°C, external static pressure at 30 Pa



[Red bar] All selections in this region will be greater than NR35.

W235 FAN COIL UNITS



These 235 mm deep units offer a selection of six widths, with volumes from 92 to 615 litres/sec and total cooling duties up to 8.72 kW with heating outputs up to 6.65 kW, based on 30 Pa external resistance.

Performance

Model/Range	Speed Range	Noise Rating † (NR)	Airflow Volume ‡ (litres/sec)	Sensible Cooling (kW)	Total Cooling (kW)	Heating (kW)	Full Load Current (Amps)
W235/105	Low	25	92	1.20	1.40	1.28	0.52
W235/105	Medium	31	115	1.50	1.70	1.47	0.52
W235/105	High	34	141	1.82	2.08	1.67	0.52
W235/208	Low	25	113	1.50	1.70	1.77	1.04
W235/208	Medium	30	185	2.40	2.70	2.42	1.04
W235/208	High	39	271	3.36	3.81	3.07	1.04
W235/310	Low	27	138	1.80	2.10	2.05	1.56
W235/310	Medium	33	262	3.34	3.77	3.06	1.56
W235/310	High	42	397	4.60	5.09	3.95	1.56
W235/312	Low	27	145	1.90	2.20	2.29	1.56
W235/312	Medium	33	269	3.50	4.00	3.39	1.56
W235/312	High	42	404	5.00	5.68	4.37	1.56
W235/414	Low	30	180	2.30	2.70	2.82	2.08
W235/414	Medium	36	337	4.30	5.00	4.18	2.08
W235/414	High	44	509	6.13	6.89	5.42	2.08
W235/517	Low	31	204	2.60	3.10	3.32	2.60
W235/517	Medium	38	401	5.20	6.00	5.09	2.60
W235/517	High	45	615	7.62	8.72	6.65	2.60

* Cooling duties are based on Chilled Water (CW) on/off at 6°C/12°C, with air on at 23°C/16°C dry/wet bulb.

Heating duties are based on Low Pressure Hot Water (LPHW) on/off at 80°C/70°C, with air on at 20°C.

For other water temperatures, apply 'Water Temperature Correction Factors' from the table below.

Dimensions

Model/Range		W235/105	W235/208	W235/310	W235/312	W235/414	W235/517
Length (Excluding Plenum)	mm	800	800	800	800	800	800
Optional Inlet Plenum	mm	450	450	450	450	450	450
Nominal Width	mm	600	900	1050	1250	1450	1750
Depth	mm	235	235	235	235	235	235
Number of Fans		1	2	3	3	4	5
Maximum Number of 197 mm OD Spigots		4	5	5	6	6	7
Unit Weight	kg	35	40	50	55	70	90

Water Temperature Correction Factors

Low Pressure Hot Water		Chilled Water	
Temperature °C	Factor	Temperature °C	Factor
80/70	1.00	6/12	1.00
70/60	0.79	7/12	1.00
60/50	0.59	10/15	0.68

Notes:

* All cooling and heating duties shown are coil duties only and do not allow for any fan motor or duct gains.

† All NR figures have been calculated making the following assumptions:

(a) Room absorption of 8 dB.

(b) Ceiling loss of: dB 4 7 9 11 14 16
In the frequency of: Hz 125 250 500 1k 2k 4k

(c) A one metre length of non-regenerative, unlined PVC flexible ducting being fitted in each supply duct, and a maximum air velocity of 3 m/sec at each outlet spigot.

(d) Reverberant field.

‡ All airflow volumes shown are based upon 30 Pa external static resistance. Chilled water values based on total cooling.

W285A FAN COIL UNITS



This 285 mm deep range has a choice of five widths, with volumes from 83 to 682 litres/sec and total cooling duties up to 9.39 kW with heating outputs up to 7.1 kW, based on 30 Pa external resistance.

The W285A is a compact unit excluding plenum.

Performance

Model/Range	Speed Range	Noise Rating † (NR)	Airflow Volume ‡ (litres/sec)	Sensible Cooling (kW)	Total Cooling (kW)	Heating (kW)	Full Load Current (Amps)
W285A/105	Low	25	83	1.10	1.30	1.20	0.52
W285A/105	Medium	31	115	1.50	1.70	1.47	0.52
W285A/105	High	36	148	1.90	2.16	1.72	0.52
W285A/208	Low	25	165	2.10	2.50	2.26	1.04
W285A/208	Medium	31	226	2.92	3.33	2.74	1.04
W285A/208	High	38	288	3.53	3.99	3.19	1.04
W285A/312	Low	26	142	1.80	2.20	2.26	1.56
W285A/312	Medium	33	289	3.70	4.30	3.57	1.56
W285A/312	High	41	466	5.59	6.30	4.77	1.56
W285A/414	Low	27	193	2.50	2.90	2.95	2.08
W285A/414	Medium	35	374	4.82	5.50	4.47	2.08
W285A/414	High	43	582	6.79	7.59	5.88	2.08
W285A/517	Low	30	242	3.10	3.70	3.71	2.60
W285A/517	Medium	37	445	5.70	6.60	5.43	2.60
W285A/517	High	45	682	8.25	9.39	7.10	2.60

* Cooling duties are based on Chilled Water (CW) on/off at 6°C/12°C, with air on at 23°C/16°C dry/wet bulb.

Heating duties are based on Low Pressure Hot Water (LPHW) on/off at 80°C/70°C, with air on at 20°C.

For other water temperatures, apply 'Water Temperature Correction Factors' from the table below.

Dimensions

Model/Range		W285A/105	W285A/208	W285A/312	W285A/414	W285A/517
Length (Excluding Plenum)	mm	900	900	900	900	900
Optional Inlet Plenum	mm	600	600	600	600	600
Nominal Width	mm	600	900	1250	1450	1750
Depth	mm	285	285	285	285	285
Number of Fans		1	2	3	4	5
Maximum Number of 247 mm OD Spigots		4	5	6	6	7
Unit Weight	kg	37	42	58	73	94

Water Temperature Correction Factors

Low Pressure Hot Water		Chilled Water	
Temperature °C	Factor	Temperature °C	Factor
80/70	1.00	6/12	1.00
70/60	0.79	7/12	1.00
60/50	0.59	10/15	0.68

Notes:

* All cooling and heating duties shown are coil duties only and do not allow for any fan motor or duct gains.

† All NR figures have been calculated making the following assumptions:

(a) Room absorption of 8 dB.

(b) Ceiling loss of: dB 4 7 9 11 14 16
In the frequency of: Hz 125 250 500 1k 2k 4k

(c) A one metre length of non-regenerative, unlined PVC flexible ducting being fitted in each supply duct, and a maximum air velocity of 3 m/sec at each outlet spigot.

(d) Reverberant field.

‡ All airflow volumes shown are based upon 30 Pa external static resistance.

Chilled water values based on total cooling.

W335Q FAN COIL UNITS



The largest unit in the range is 335 mm deep and has a choice of two widths, with volumes from 212 to 750 litres/sec and total cooling duties up to 11 kW with heating outputs up to 17.1 kW, based on 30 Pa external resistance.

Performance

Model/Range	Speed Range	Noise Rating † (NR)	Airflow Volume ‡ (litres/sec)	Sensible Cooling (kW)	Total Cooling (kW)	Heating (kW)	Full Load Current (Amps)
W335Q/414	Low	28	212	2.70	3.30	6.70	2.08
W335Q/414	Medium	36	411	5.30	6.20	10.60	2.08
W335Q/414	High	44	640	8.30	9.40	14.30	2.08
W335Q/517	Low	30	266	3.40	4.10	8.39	2.60
W335Q/517	Medium	37	515	6.70	7.80	13.30	2.60
W335Q/517	High	45	750	9.70	11.00	17.10	2.60

* Cooling duties are based on Chilled Water (CW) on/off at 6°C/12°C, with air on at 23°C/16°C dry/wet bulb.

Heating duties are based on Low Pressure Hot Water (LPHW) on/off at 80°C/70°C, with air on at 20°C.

For other water temperatures, apply 'Water Temperature Correction Factors' from the table below.

Dimensions

Model/Range		W335Q/414	W335Q/517
Length (Including Inlet Plenum)	mm	1500	1500
Nominal Width	mm	1450	1750
Depth	mm	335	335
Number of Fans		4	5
Maximum Number of 247 mm OD Spigots		6	7
Unit Weight	kg	130	150

Water Temperature Correction Factors

Low Pressure Hot Water		Chilled Water	
Temperature °C	Factor	Temperature °C	Factor
80/70	1.00	6/12	1.00
70/60	0.79	7/12	1.00
60/50	0.59	10/15	0.68

Notes:

* All cooling and heating duties shown are coil duties only and do not allow for any fan motor or duct gains.

† All NR figures have been calculated making the following assumptions:

(a) Room absorption of 8 dB.

(b) Ceiling loss of: dB 4 7 9 11 14 16
In the frequency of: Hz 125 250 500 1k 2k 4k

(c) A one metre length of non-regenerative, unlined PVC flexible ducting being fitted in each supply duct, and a maximum air velocity of 3 m/sec at each outlet spigot.

(d) Reverberant field.

‡ All airflow volumes shown are based upon 30 Pa external static resistance.

Chilled water values based on total cooling.

GENERAL ARRANGEMENT

W235 (Size 414 viewed from above with optional unlined inlet plenum and LH controls)

Model W235 (Range)	Nominal Width (mm)	Maximum Number of Spigots	Number of Fans
105	600	4	1
208	900	5	2
310	1050	5	3
312	1250	6	3
414	1450	6	4
517	1750	7	5

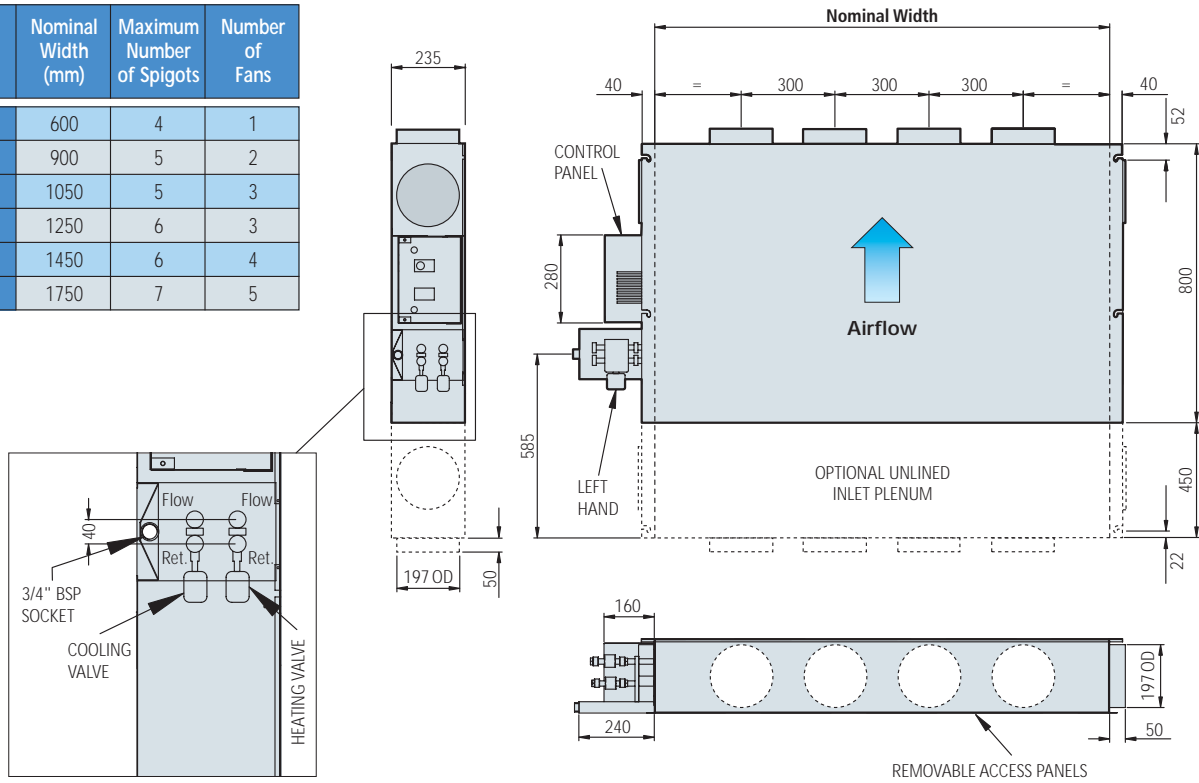

W285A (Size 414 viewed from above with optional unlined inlet plenum and LH controls)

Model W285A (Range)	Nominal Width (mm)	Maximum Number of Spigots	Number of Fans
105	600	4	1
208	900	5	2
312	1250	6	3
414	1450	6	4
517	1750	7	5

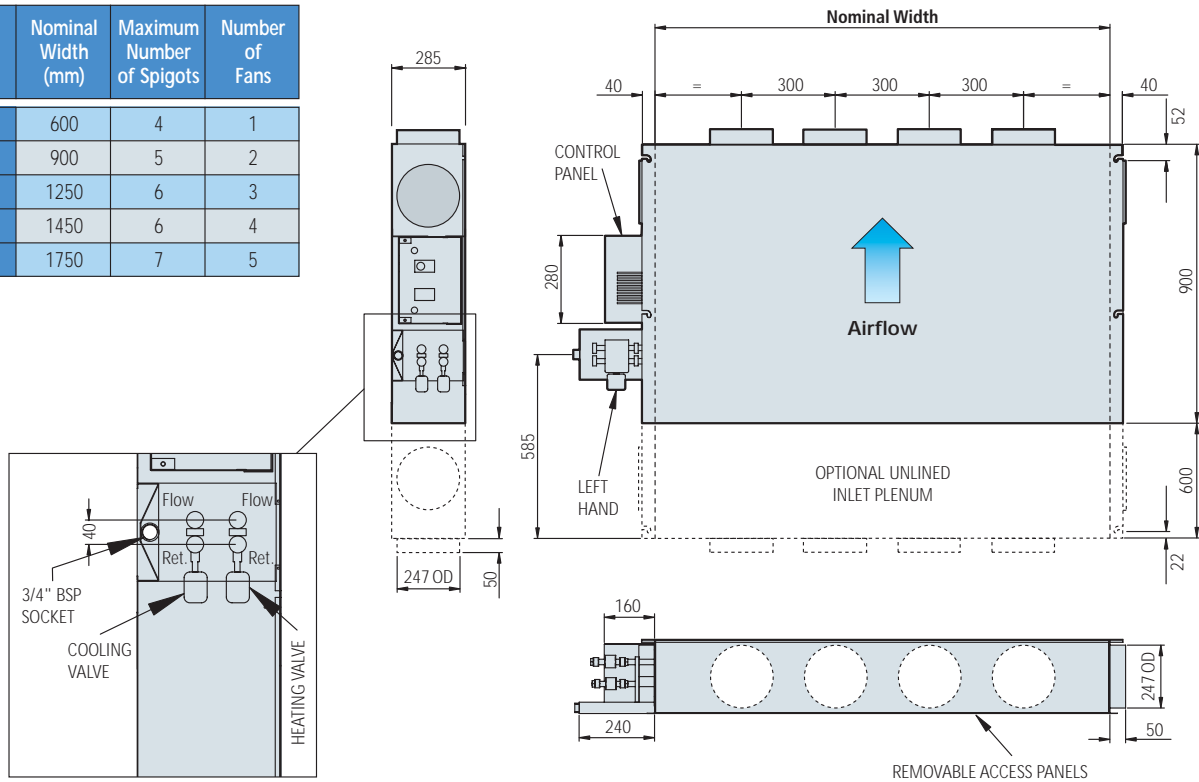

GENERAL ARRANGEMENT & ELECTRICAL INFORMATION

W335Q (Size 414 viewed from above with integral lined inlet plenum and LH controls)

Model W335Q (Range)	Nominal Width (mm)	Maximum Number of Spigots	Number of Fans
414	1450	6	4
517	1750	7	5

* Control panel length dimension varies:
 W335/Q414 is 280 mm wide.
 W335/Q517 is 430 mm wide.

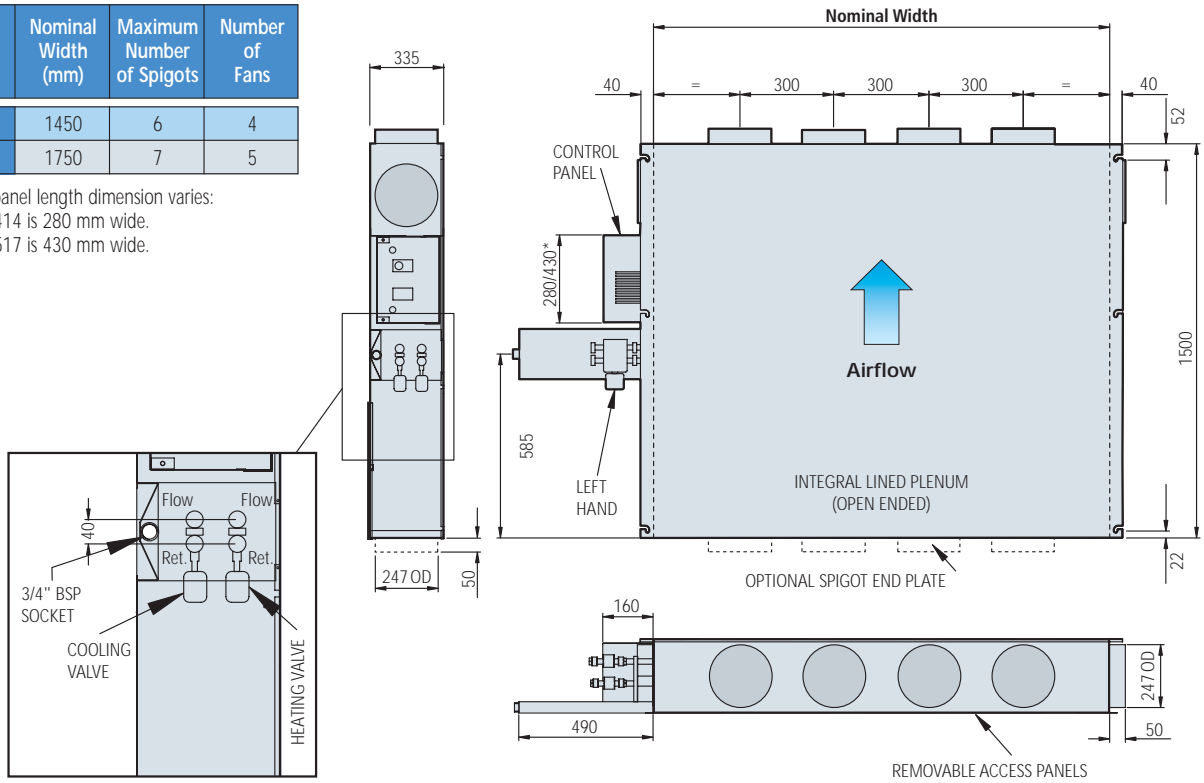

Electrical Information

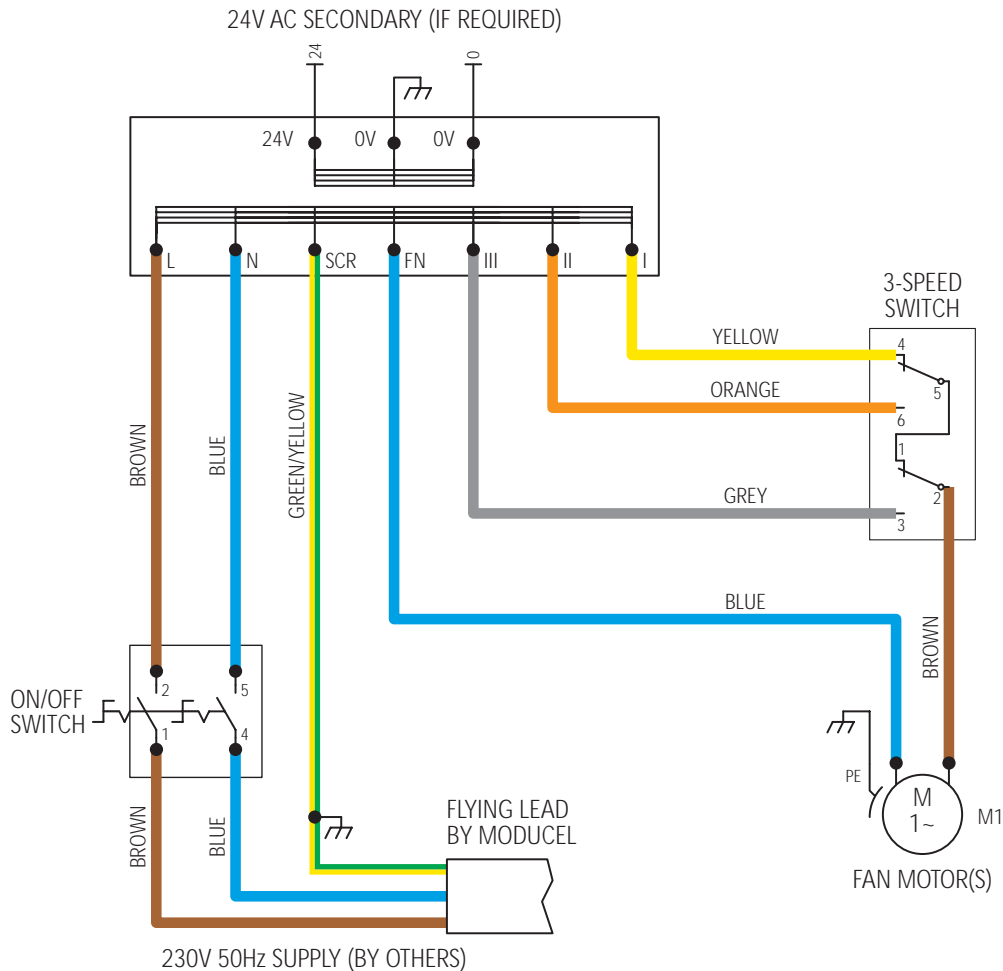

ORDERING INFORMATION

Options and Order Codes

Fan Coil Unit Selection

MODEL/RANGE	SPEED	HANDING	ACCESS	CONTROLLER MANUFACTURER	CONTROL TYPE	SENSOR TYPE	INLET PLENUM
W235/105	L Low	LH Left hand coil (in direction of airflow)	BOT Bottom	SIE Siemens	HC Heat cool (Standalone)	RA Return air type	IP Only W235 and W285A units can be selected without an inlet plenum
W235/208	M Medium		TOP Top	FSIE Free Issue Siemens	C Cool only (Standalone)	RS Room type	
W235/310	H High		TPF Top with feet	L10 Trend (IQL10)	H Heat only (Standalone)	RS3 Room type (3-speed switch)	
W235/312		RH Right hand coil (in direction of airflow)		FL10 Free Issue Trend (IQL10)	HCI Heat cool (Intelligent)		
W235/414				L11 Trend (IQL11)	CI Cool only (Intelligent)		
W235/517				FL11 Free Issue Trend (IQL11)	HI Heat only (Intelligent)		
W285A/105				211 Trend (IQ211)	HCM Heat cool (Master)	RSS Room sensor with set-point adjustment	
W285A/208				F211 Free Issue Trend (IQ211)	CM Cool only (Master)		
W285A/312				EWE Eaton-Williams electronic controls package	HM Heat only (Master)		
W285A/414					HCM Heat cool (Master Intelligent)		
W285A/517					CMI Cool only (Master Intelligent)		
W335Q/414					HMI Heat only (Master Intelligent)		
W335Q/517					HCS Heat cool (Slave)		
					CS Cool only (Slave)		
					HS Heat only (Slave)		
					HCSI Heat only (Slave Intelligent)		
					CSI Cool only (Slave Intelligent)		
					HSI Heat only (Slave Intelligent)		

MODEL/RANGE SPEED HANDING ACCESS CONTROLLER MANUFACTURER CONTROL TYPE SENSOR TYPE INLET PLENUM

W235/414 L LH BOT SIE HC RS3 IP

Fan Coil Unit — Optional Extras

HEAT/COOL VALVES	BINDER POINTS	CONDENSATE PUMP	DISCHARGE SPIGOT	DRAIN TRAY
HCV Fit heat/cool valves to coil CLV Fit cool only valves to coil HTV Fit heat only valves to coil	BP2 Supply and fit 2 off binder points BP4 Supply and fit 4 off binder points	FCP Fit Free Issue condensate pump MCP Supply and fit Masterway condensate pump OCP Supply and fit Osaka condensate pump ACP Supply and fit Aspen condensate pump	RSP Rectangular discharge spigot	ED Extended drain tray MD Masterway drain tray (selected with Masterway condensate pump) OD Osaka drain tray (selected with Osaka condensate pump) AD Aspen drain tray (selected with Aspen condensate pump)

HEAT/COOL VALVES BINDER POINTS CONDENSATE PUMP DRAIN TRAY

HCV BP4 OCP OD

ORDERING EXAMPLE

W235/414 L LH BOT SIE HC RS3 IP HCV BP4 OCP OD

The W235/414 unit is supplied with a low speed range, left hand coil and access to bottom of unit, Siemens controller with a heat cool (standalone) control, room type (3-speed switch) sensor, with an inlet plenum.

Optional extras fitted are heat/cool valves, 4 off binder points, supplied and fitted Osaka condensate pump and Osaka drain tray.

