

MODUCEL

80 - 120 KW
DOWNFLOW COOLING



DRU

DRU
DATA ROOM UNITS

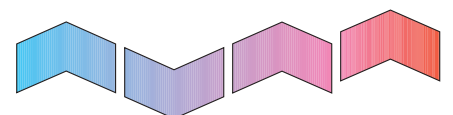

DATA ROOM UNITS

The Moducel range of high efficiency Data Room Units, are designed for high density load areas where a large cooling duty is required from a compact footprint, but without compromising the critical application of data centre cooling.

This downflow range of air conditioning units are available in DX air cooled, water cooled or chilled water media with optional glycol cooling. All configurations have energy reduction features as well as heating or humidification options.

The DRU Range has been designed around a modular frame and panel design providing maximum unit strength as well as all round access where applicable. However, all maintenance and service has been designed for front access only where site restrictions dictate.

The units are designed to take return air at a high level which is then filtered and conditioned before being discharged via the base fan section located in the ventilated raised floor.

Multiple high efficiency direct drive fans provide even, efficient air supply and inherent redundancy. Alternatively, the units can be fitted with speed controllable EC fans.

All DX units are supplied with twin compressor 4-stage cooling, whilst chilled water units provide stepless 0 to 100% cooling. Where applicable glycol economy cooling coils can be coupled to dry coolers or economy cooling chillers to maximise efficiency and minimise running costs.

Where required, the units can be supplied with electrode boiler humidifiers providing high efficiency stepless output of sterile steam, and electric heaters are available in case of reheat requirement.



Model DRU8 shown.

Features

| |
|--|
| Multiple key components share system loads: |
| Vertical AHU frame and panel construction: |
| Modular split fan / coil sections: |
| Underfloor multiple backward curved fans: |
| Hydrophilic coils: |
| Modular component assembly: |
| Fully programmable DDC controller: |
| Customised control systems: |

Benefits

| |
|--|
| Increased efficiency and reduced system impact in the unlikely event of a key component failure. |
| All round access and high unit strength and rigidity. |
| Ease of installation. |
| Efficient air distribution. |
| Long life and efficient moisture removal. |
| Designed for easy and quick component maintenance/ replacement. |
| Customised programming and network capabilities. |
| Ease of integration for existing site upgrades. |

UNIT FEATURES



1



2



- 1. Fan Section.
- 2. Electrical Section.
- 3. Compressor Section.

3



DRUI

TECHNICAL SPECIFICATION

| Model | DRU8 | DRU10 | DRU12 |
|-------|------|-------|-------|
|-------|------|-------|-------|

DX SYSTEM

| | | | | |
|------------------------|----|----|----|-----|
| Total Cooling | kW | 74 | 97 | 120 |
| Gross Sensible Cooling | kW | 61 | 85 | 96 |
| Net Sensible Cooling | kW | 54 | 75 | 85 |

CHILLED WATER SYSTEM

| | | | | |
|------------------------|----|------|------|-------|
| Total Cooling | kW | 81.4 | 98.6 | 126.4 |
| Gross Sensible Cooling | kW | 73.4 | 92.8 | 112.4 |
| Net Sensible Cooling | kW | 70.9 | 89.1 | 108.7 |

AIR MOVEMENT

| | | | | |
|-------------------------------------|---------------------------------------|--------------|-------------|-------------|
| Air Volume | m ³ /s (m ³ /h) | 4.65 (16740) | 7.0 (25200) | 7.0 (25200) |
| Design External Pressure Drop | Pa | 20 | 20 | 20 |
| Number of Fans | | 2 | 3 | 3 |
| Nominal Power Consumption (per Fan) | kW | 2.5 | 2.5 | 2.5 |

REFRIGERATION

| | | | | |
|-----------------------|--|-------|-------|-------|
| Number of Compressors | | 2 | 2 | 2 |
| Refrigerant | | R407c | R407c | R407c |

HEATING

| | | | | |
|----------------------|----|-----|-----|-----|
| Stages | | 2 | 2 | 2 |
| Capacity (per Stage) | kW | 7.5 | 7.5 | 7.5 |

HUMIDIFICATION

| | | | | |
|-------------------------|-------|------------------|------------------|------------------|
| Humidifier | | Electrode Boiler | Electrode Boiler | Electrode Boiler |
| Humidification Capacity | Kg/hr | 15 | 15 | 15 |

DRU — INDOOR UNIT

| | | | | |
|--|----|--------------------|--------------------|--------------------|
| Dimensions (Including Fan Base) — Width x Height x Depth | mm | 1700 x 3090 x 1090 | 2460 x 3090 x 1090 | 2460 x 3090 x 1090 |
| Filtration | | EU4 | EU4 | EU4 |
| Unit Weight** | Kg | 678 | 921 | 963 |
| Fan Base Weight | Kg | 223 | 335 | 335 |

INCO DX CONDENSER — OUTDOOR UNIT

| | | | | |
|-------------------------------------|----|----------------------|----------------------|----------------------|
| Condensers | | 2 x INCO 2-2 | 2 x INCO 2-4 | 2 x INCO 3-2 |
| Dimensions — Width x Height x Depth | mm | 2407 x 1100 x 1025.5 | 2407 x 1100 x 1025.5 | 3507 x 1100 x 1025.5 |
| Weight | Kg | 170 | 210 | 240 |

POWER SPECIFICATION FOR ALL SYSTEMS

| | | | | |
|--------------|---------|----------|----------|----------|
| Power Supply | V/PH/Hz | 400/3/50 | 400/3/50 | 400/3/50 |
|--------------|---------|----------|----------|----------|

POWER CONSUMPTION — AIR COOLED

| | | | | |
|---|---------|------|------|------|
| Cooling Only Unit (Fans & Compressors) | a/phase | 54.5 | 67.5 | 88.5 |
| Temperature Unit (Fans, Compressors & Heaters)* | a/phase | 54.5 | 67.5 | 88.5 |
| Full AC Unit | a/phase | 75.5 | 89 | 110 |

POWER CONSUMPTION — WATER COOLED

| | | | | |
|---|---------|------|----|-----|
| Cooling Only Unit (Fans & Compressors) | a/phase | 51 | 64 | 82 |
| Temperature Unit (Fans, Compressors & Heaters)* | a/phase | 51 | 64 | 82 |
| Full AC Unit | a/phase | 75.5 | 89 | 103 |

POWER CONSUMPTION — CHILLED WATER

| | | | | |
|---|---------|----|----|----|
| Cooling Only Unit (Fans & Compressors) | a/phase | 12 | 17 | 17 |
| Temperature Unit (Fans, Compressors & Heaters)* | a/phase | 34 | 39 | 39 |
| Full AC Unit | a/phase | 55 | 60 | 60 |

Notes

DX Unit cooling duties are based on 24°C / 45% Relative Humidity / 35°C Ambient.

Chilled Water (CW) Unit cooling duties are based on 24°C / 45% Relative Humidity and 6°C Flow / 11°C Return.

*No humidity control. **DX Air Cooled Unit.

CONTROLLER



The DRU is fitted with a fully programmable unitary controller complete with display/user interface. The controller monitors the temperature and relative humidity of the return air and activates cooling humidification or dehumidification to provide precise and efficient conditioning of the supply air.

Additionally, the controller monitors the in-built safety devices of the unit which constantly ensure the healthy state of key components. In the unlikely event of a component malfunction the item is automatically isolated to enable the plant to continue running, and an alarm signal will be generated.

Where required, multiple units can be networked together to provide group or run/standby control.

Units can be monitored locally or remotely, and if required, an enhanced 'web enabled' controller can be supplied, providing password restricted access from a suitable Internet access point.

Control Features

- Fully programmable.
- Data logging.
- Standalone or group control.
- BMS interface.
- Remote monitoring.
- Energy saving control strategies.

Monitored Information and Alarm Points

- Temperature.
- Relative humidity.
- Airflow.
- Filter condition.
- Refrigerant monitoring.
- Water detection.
- Humidifier status.
- Heater status.
- Fire shutdown.
- VFC relay alarms.
- Smoke detection.

SYSTEM SELECTION

Air Cooled

The air cooled DX system circulates refrigerant to absorb heat from the conditioned space at the indoor unit, which is then rejected at the external air cooled condenser.

Twin evaporator coil / compressor circuits with multiple supply fans, provide redundancy with four stages of cooling and are coupled to two individual low noise level air cooled condensers, complete with fan speed controls.

Optional humidification control can be provided by an electrode boiler humidifier, and optional heaters provide reheat where required during dehumidification mode.

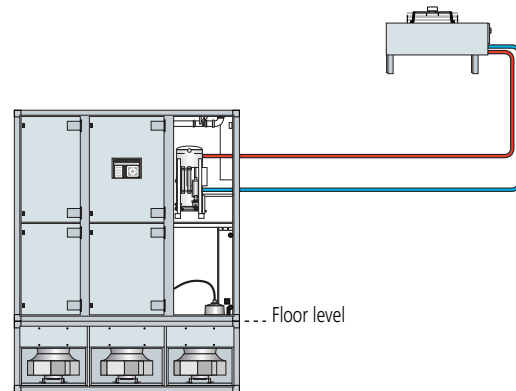

Water Cooled

The water cooled DX system circulates refrigerant to absorb heat from the conditioned space at the indoor unit, which is then rejected via an external dry cooler or similar.

Twin evaporator coil / compressor circuits with multiple supply fans, provide redundancy with four stages of cooling and are coupled with an individual plate heat exchanger for water cooled heat rejection, complete with three port head pressure control valves.

Optional humidification control is provided by an electrode boiler humidifier and optional heaters provide reheat where required during dehumidification mode.

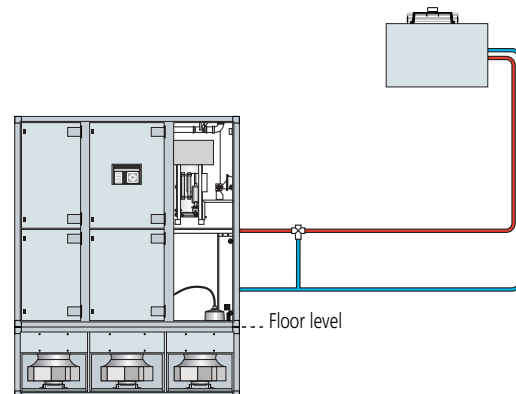

Water Cooled with Glycol Economy Cooling

The water cooled DX system circulates refrigerant to absorb heat from the conditioned space at the indoor unit, which is then rejected via an external dry cooler or similar.

Twin evaporator coil / compressor circuits with multiple supply fans provide redundancy with four stages of cooling and are coupled with an individual plate heat exchanger for water cooled heat rejection, complete with three port head pressure control valves. An additional glycol cooling coil provides low energy cooling when ambient conditions dictate.

Optional humidification control is provided by an electrode boiler humidifier and optional heaters provide reheat where required during dehumidification mode.

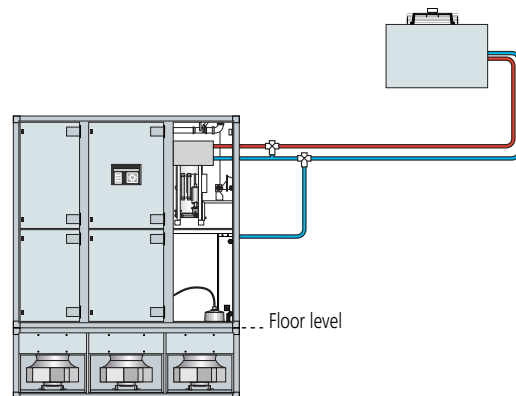

Chilled Water

The chilled water system circulates water to absorb heat from the conditioned space at the indoor unit which is then rejected at the external chiller.

Twin cooling coil with multiple supply fans provide fully modulating 0 to 100% cooling complete with two or three port control valves.

Optional humidification control is provided by an electrode boiler humidifier and optional heaters provide reheat where required by the dehumidification mode.

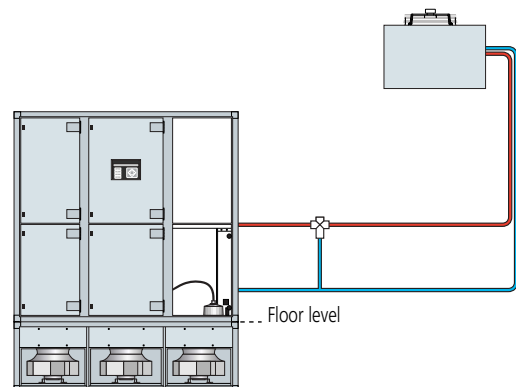

SYSTEM CONFIGURATIONS

Air Cooled

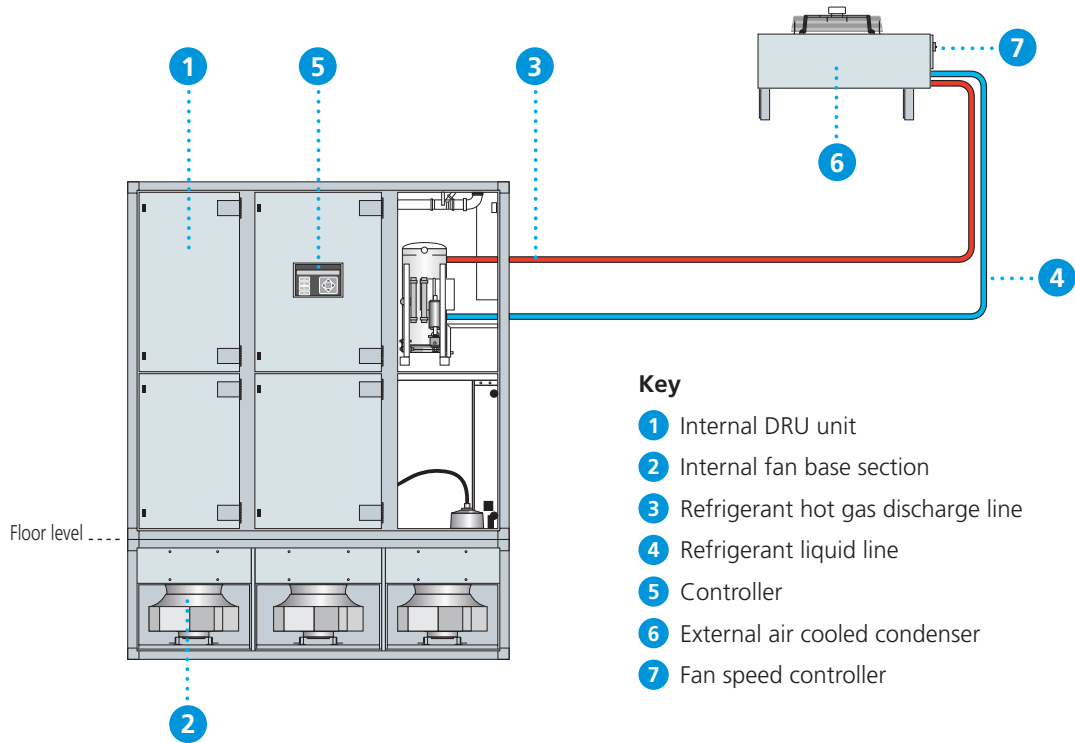

Water Cooled

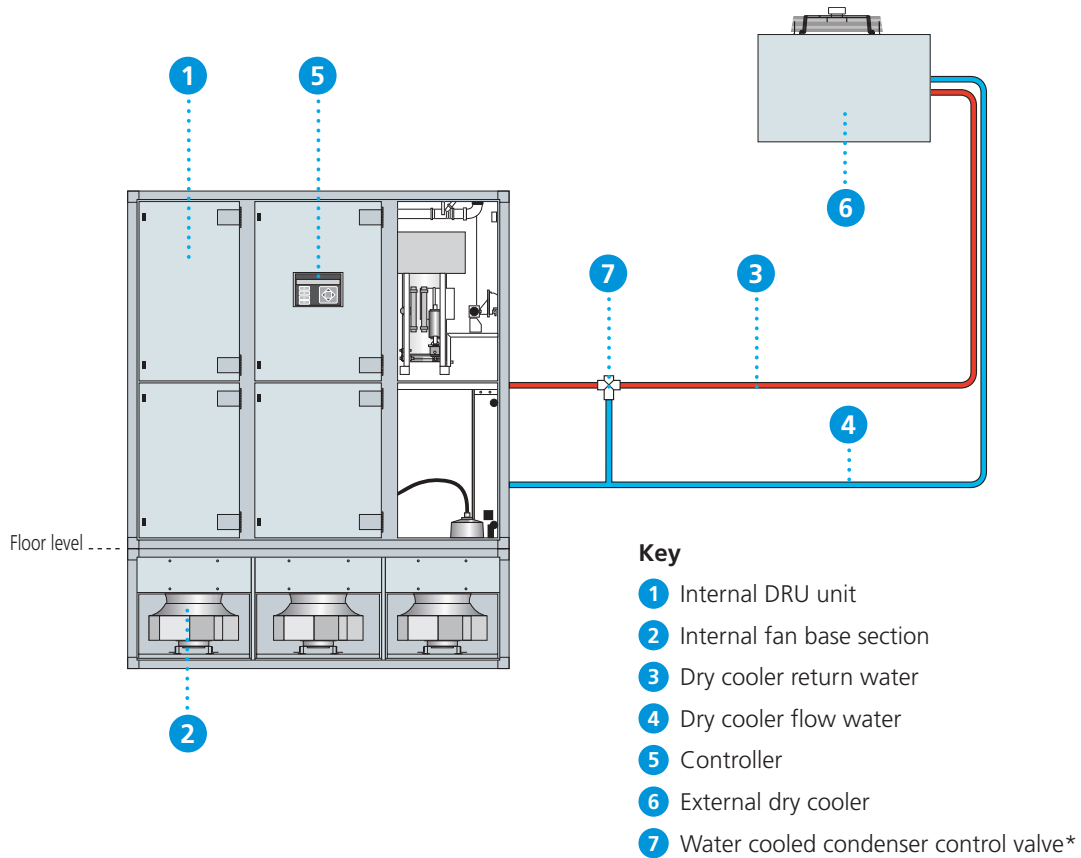

* The valves depicted are purely shown schematically and are physically located within the unit.

SYSTEM CONFIGURATIONS

Water Cooled Glycol Economy Cooling

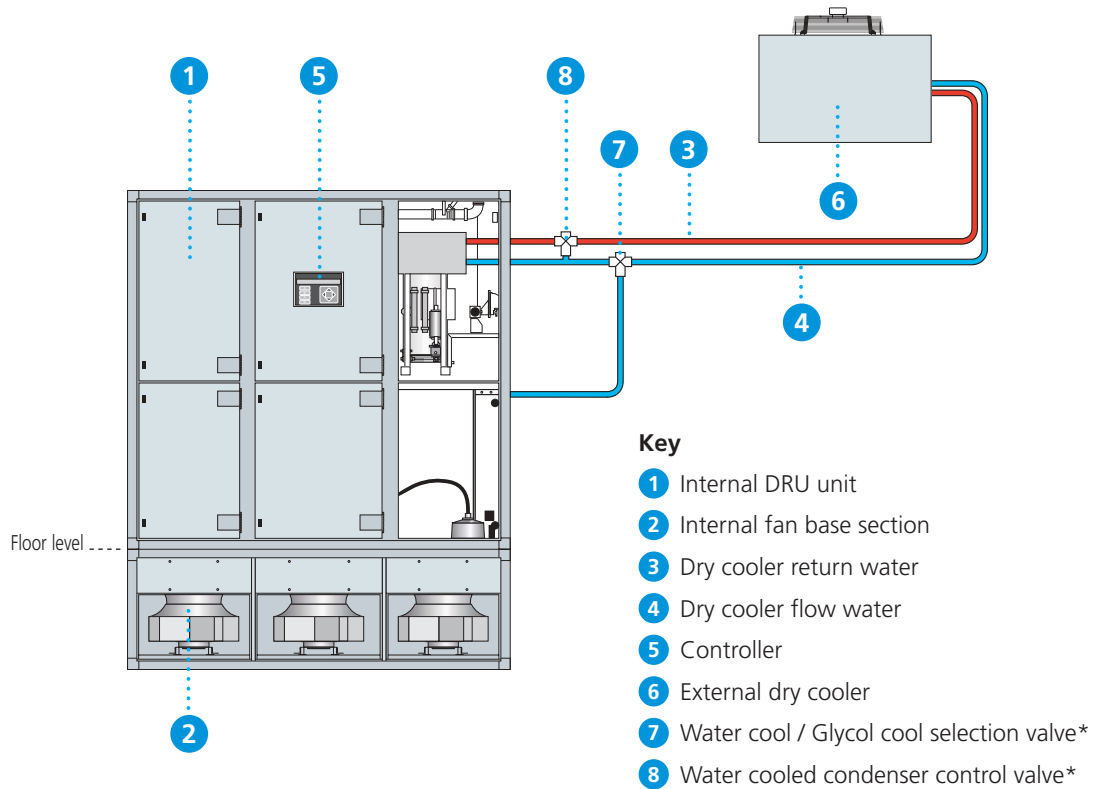

Chilled Water

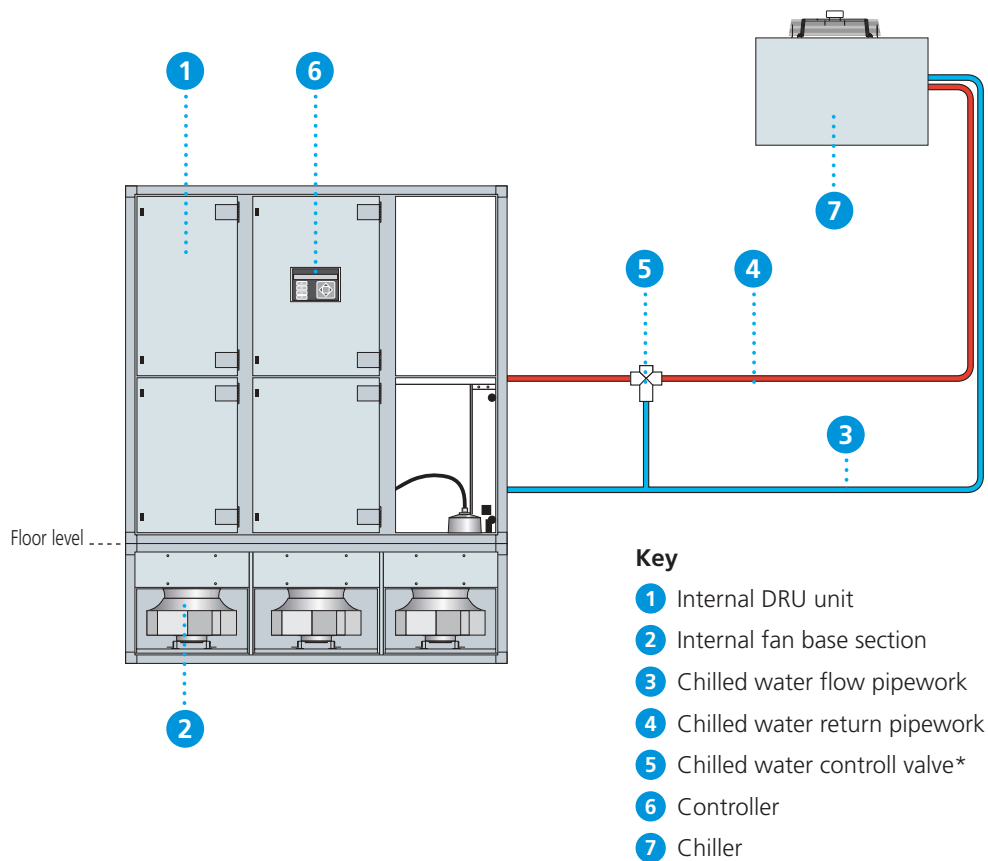

* The valves depicted are purely shown schematically and are physically located within the unit.

UNIT DIMENSIONS

DRU8

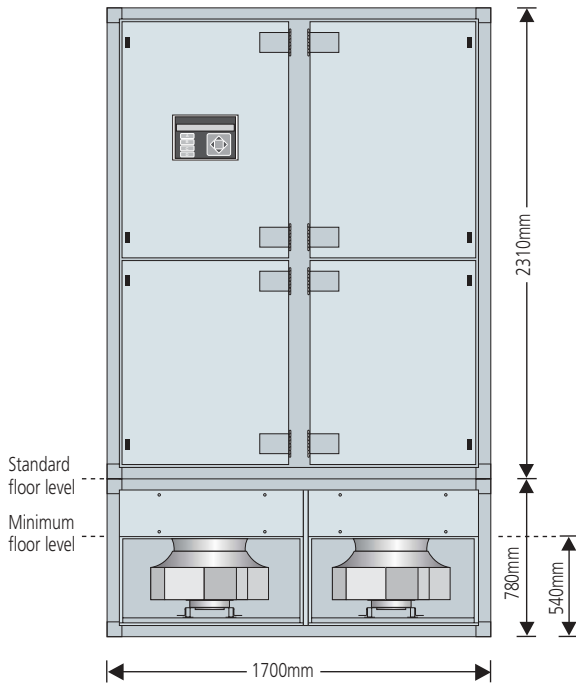

DRU10

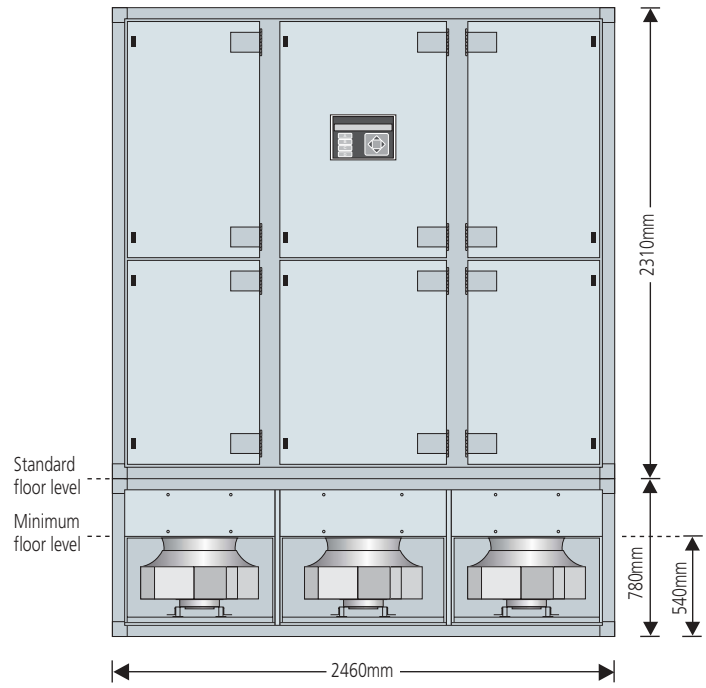

DRU12

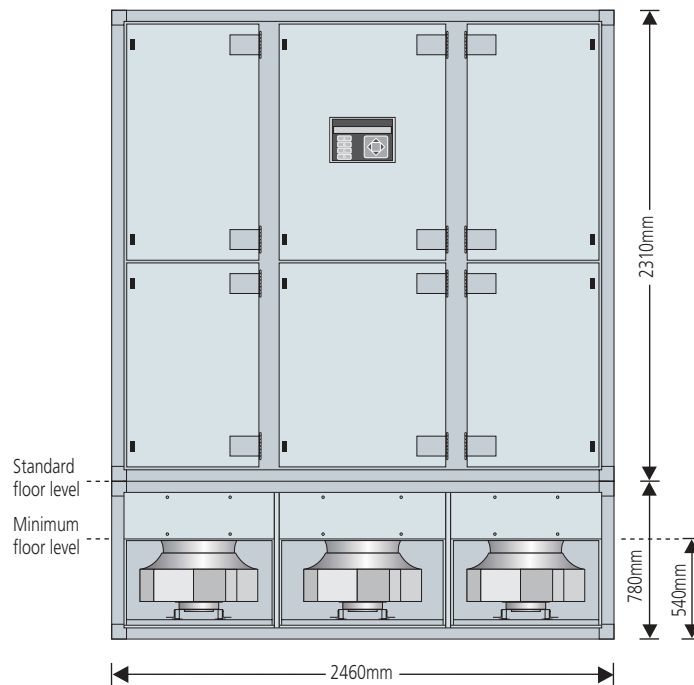

Note: All DRU units are 1090mm deep.

INCO DX AIR COOLED CONDENSER

Twin Fan Unit

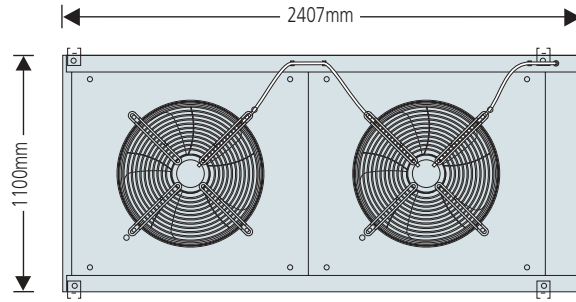

Triple Fan Unit

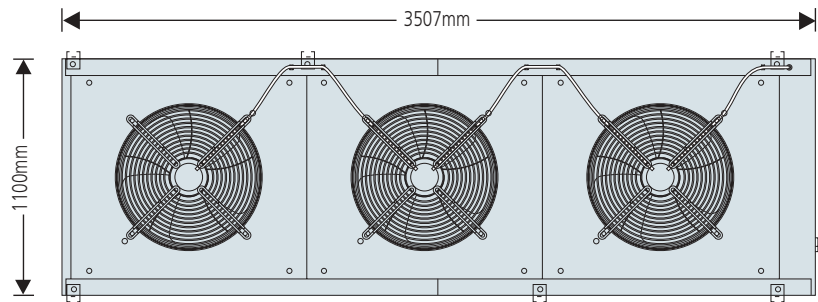

Horizontal Mount
(Vertical Air Flow)
Elevation

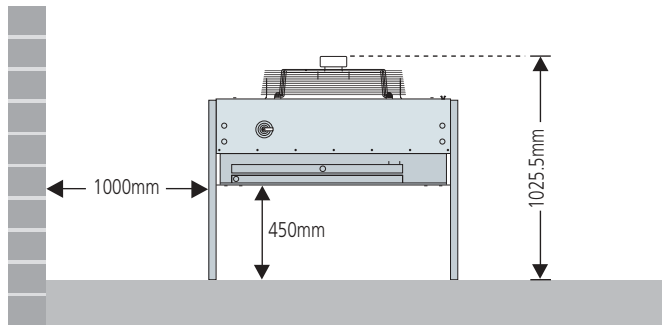

Vertical Mount
(Horizontal Air Flow)
Elevation

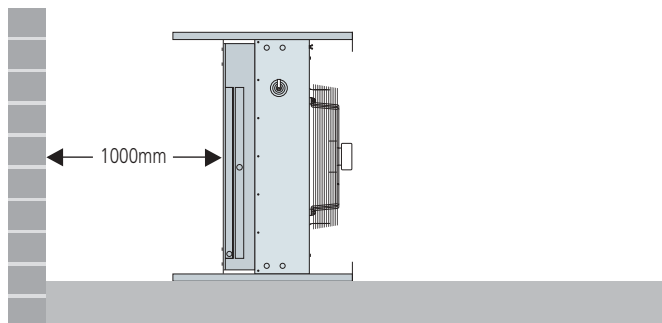

GROUP PRODUCTS & SERVICES



Server Cabinets & Rear Door Heat Exchangers (RDHx)

Powerful cooling capacity, up to 30kW heat removed at source and rejected to water, not the room. Condense free operation using dew point controlled water from the CDU. 6 'hot swap' fans – variable speed. 80% front door venting. 1,000kg weight loading and full range of accessories. Easily installed via leak free quick release 3/4" couplings and hose sets.

600mm wide – 20kW cooling.
800mm wide – 30kW cooling.



CDU (Cooling Distribution Unit)

Provides cooling water for up to 6 rear door heat exchangers. Cooling capacities of 100, 120 or 150kW with full run/standby capability (N+1). Internal manifold with leak free quick release couplings for easy installation and connection to the rear door heat exchangers via 3/4" hose sets. Chilled water connections (42mm / 1 1/2") via top or bottom. Dew point temperature control of cooling water, internal CW filtration. Auto fill and bleed of coolant. Full alarm monitoring and connectivity.



CDU Module

The 20kW CDU Module is a 6u rack mountable, self contained cooling module capable of providing closely controlled cooling water above dew point to one or two rear door heat exchangers. Leak free, quick release couplings enable rapid install and connection to the rear door heat exchanger via 3/4" hose sets. Features include dew point temperature control for condense free operation, Auto fill and bleed of coolant, full alarm monitoring and connectivity.



Modular CDU System

A dedicated cabinet to house up to 6 CDU Modules to enable initial install to be completed allowing the perfect upgrade path. The cabinet houses power distribution and chilled water connectivity to the 6 CDU Modules via manifold and couplings. Individual CDU Modules can then be simply plugged in as the data centre expands or heat loads increase. Alarms, room temperature and humidity data are managed through the central power distribution system giving one connection point for power and alarms.



DRU (CRAC) Unit

DRU Data Room air conditioning units are designed for high density load areas where a large cooling duty is required, from a compact footprint, but without compromising the critical application of data centre cooling.

80/100/120kW cooling capacities.

Available in chilled water, DX, DX with water cooled condenser and glycol free cooling configurations. A full range of options and ancillaries are available including inbuilt humidifier for room humidity control.



IPAC (CRAC) Unit

IPAC floor standing air conditioning units are available in chilled water or DX, cooling only configuration.

15 - 80kW cooling capacities available in various configurations including up flow or down flow air path, chilled water or DX cooling. A full range of options and ancillaries are available including inbuilt humidifier for room humidity control.

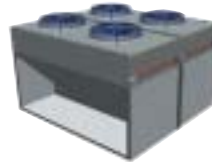

Chillers

Energy efficient chillers up to a capacity of 600kW with the full run/standby (N+1) capability can be offered. These can also be fitted with free cooling capability and qualify for ECA (Enhanced Capital Allowance) under the Carbon Trust Scheme.

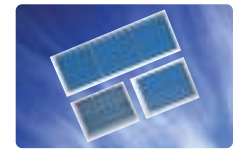

Grilles & Diffusers

Our extensive range of grilles and diffusers are available in a wide range of shapes and sizes and include floor grilles for server/data centres.



Service & Maintenance

All types of HVAC heating, ventilating and air conditioning equipment are supported by our national network of mobile engineers or residential engineers for optimum operating efficiency.



M&E Services

Project design, installation and commissioning.

Refurbishment. CFC and HCFC recovery and substitution.



Humidification

Specialist manufacturers of humidifiers and steam generation products.



Air Handling

Eaton-Williams design and manufacture air handling plant for commercial and industrial applications. Applications include hospitals, supermarket chains, leisure stadiums, pharmaceutical buildings and office complexes with uniquely designed solutions to suit each project.

PRODUCT RANGES

Computer Room & Data Centre Cooling

Air-cooled & Water-cooled Liquid Chillers

Packaged Roof-Top Units

Full Range of Air Handling Units

Fan Coil Units

Packaged Telecommunications Units

Fresh Air Units

Condensing Units

Air Cooled Condensers

Low Temperature Cassettes

Cellar & Storage Low Temperature Cooling Units

Packaged In-Wall Units

Stand-alone Humidifiers

OEM Process Cooling Control Units

Custom Designed Packages

Constant & Variable Air Volume Units

MODUCEL

Eaton-Williams Air Conditioning

Oldfields Business Park
Birrell Street, Fenton
Stoke-on-Trent ST4 3ES
Telephone: +44 (0)1782 599995
Facsimile: +44 (0)1782 599220
www.eaton-williams.com



We reserve the right to alter specifications without notice and products will sometimes be supplied with modifications which do not strictly comply with the descriptions and illustrations in this publication.

0413133 DRU /6.07/1