

# COLMAN MODUCEL

E N G I N E E R E D   A I R   D I S T R I B U T I O N

## LINEAR BAR GRILLES T SERIES

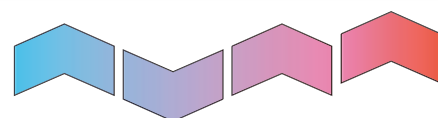
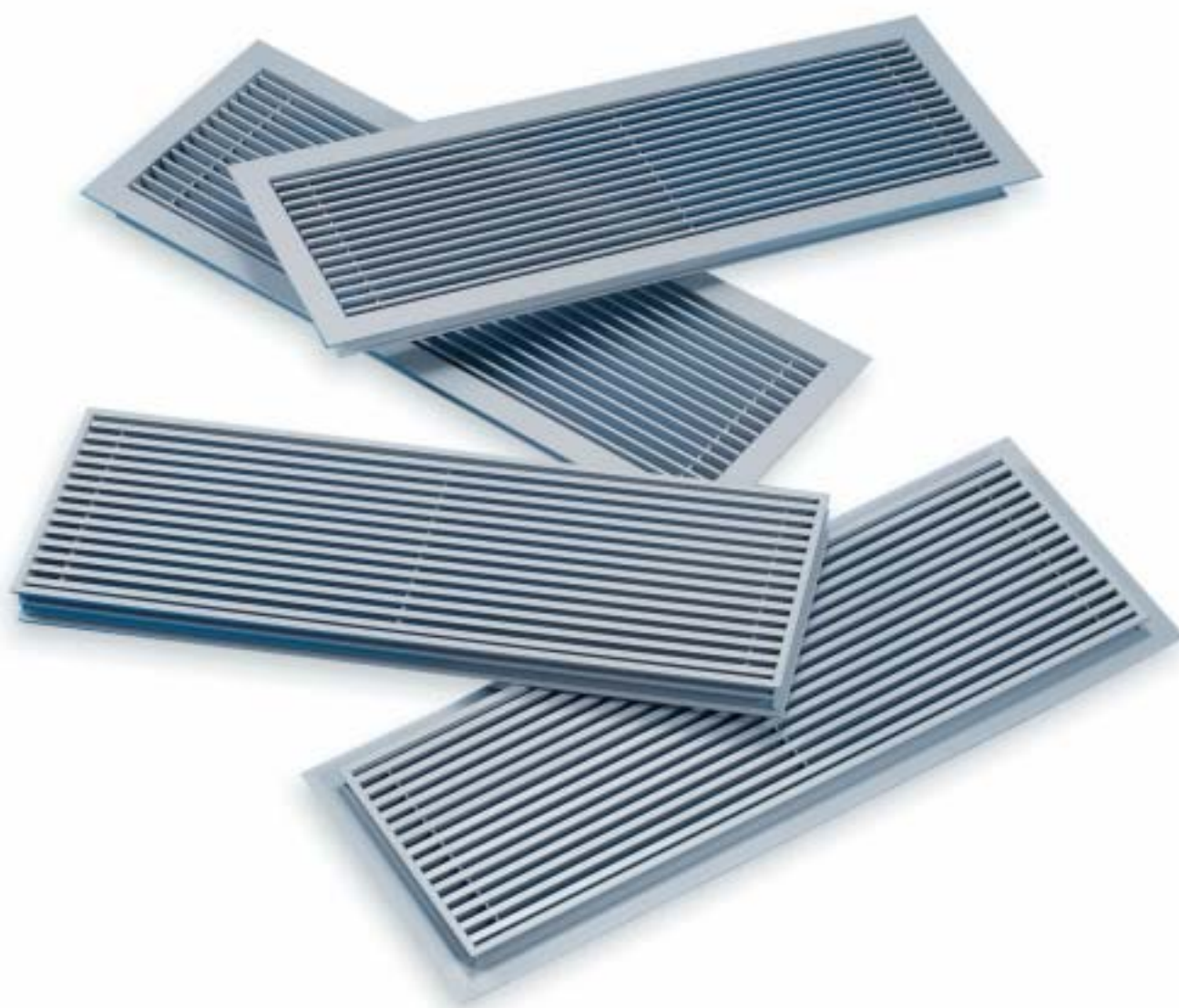

# COLMAN MODUCEL

E N G I N E E R E D   A I R   D I S T R I B U T I O N

## LINEAR BAR GRILLES T SERIES

### Introduction

Colman Moducel's 'T' Series is a comprehensive range of supply and return air linear bar grilles suitable for incorporation in ceiling, sidewall, cill and floor applications. The range includes a wide variety of frames and core styles which will co-ordinate with most building environments and provide an aesthetic and cost effective solution to the air distribution requirements.

### Frame Styles:

All frames are fabricated from high quality aluminium extrusions and are available in maximum one piece construction of 1800mm long and in increments of 12.5mm height starting from 75mm.

For continuous line application core heights are limited to a maximum of 300mm and are manufactured in equal divisions of the total length. Positive alignment keys are supplied to ensure continuous unbroken appearance.

The A frame is a surface mount design supplied with spring clip fixings, Universal mounting brackets or fixed through the face with screws. This frame style is not suitable for floor applications.

The C frame is a recess mount design that can be built into floor systems and does not require extra support brackets in this application. Please specify where the unit is being used in a floor application. Please note however

that we would not recommend Y and Z cores in floor applications.

The D frame is most suited to cill applications where visible flanges are not required.

The J frame is specifically designed for computer floor grilles when used with c core and is available in a nominal size of 600 x 600mm. The frame is suitable for a wide variety of floor systems and is made to replace a modular floor tile of thickness from 30mm to 90mm, pedestal details and tile thickness are to advised upon ordering.

Special frame styles and fixing systems are available on request.

The A Frame



The C Frame

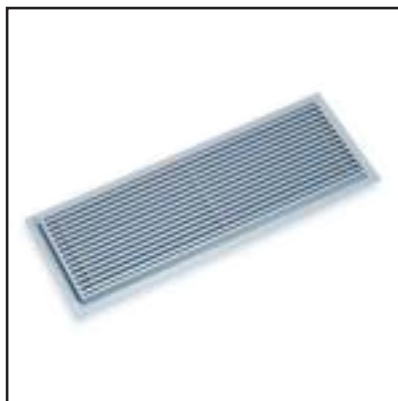

The D Frame

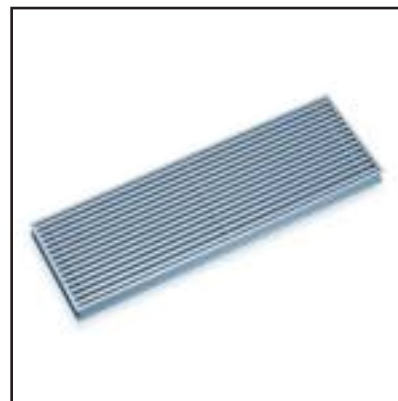

## Core Styles

All cores are fabricated from high quality aluminium extrusions with solid bars and differing angles of deflection. Units are manufactured using fixed spacing aluminium

cross members. C & D cores are available in mitred sections which are available to any angle.

Standard cores are fixed but optional removable cores are available on floor or cill

applications on request, and volume control dampers which are operable from the face of the grille are also available.

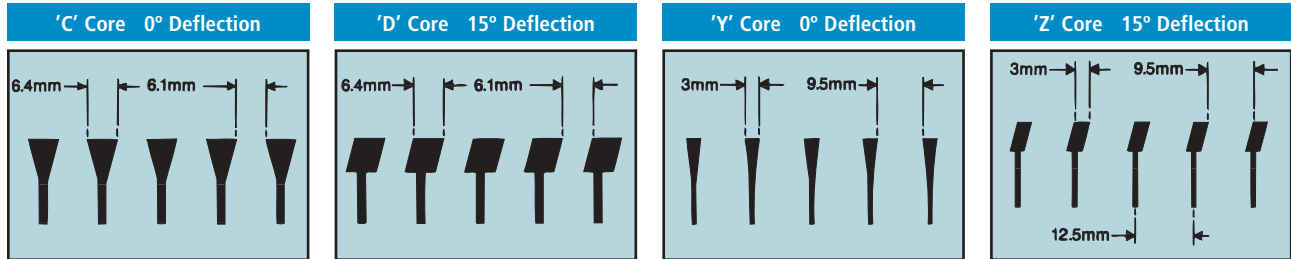

## Frame Styles Options

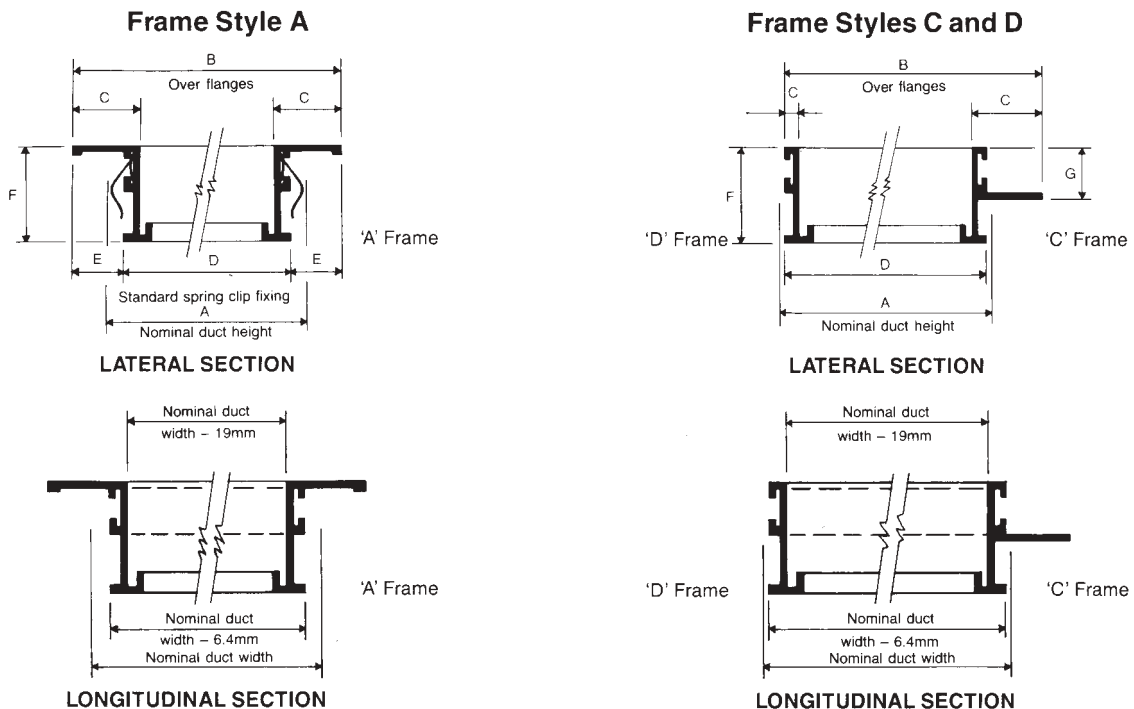

Models	A	B	C	D	E	F	G
TAC, TAD, TAY, TAZ	Nominal duct height	A + 31	25.4	A - 6.4	19	35	-
TCC, TCD		A + 35	27.4	A - 6.4	21	35	19
TDC, TDD		A - 6	6.4	A - 6.4	-	35	-

## Model TJJ Computer floor grille

**Cores:** The frames indicated above are available in combination with cores shown

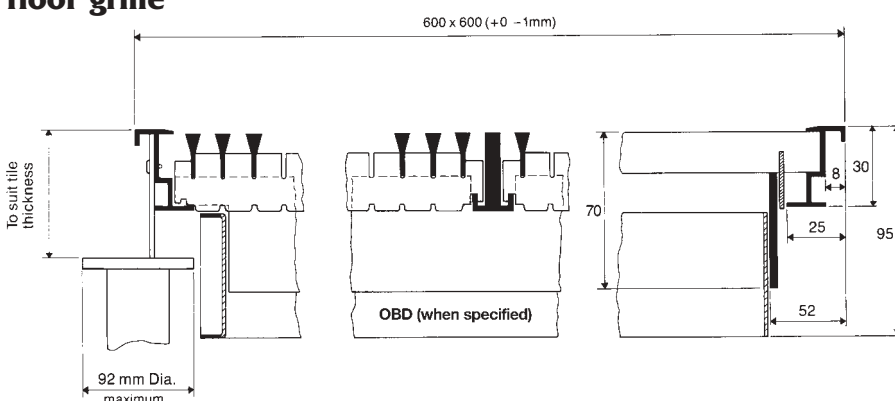

Nominal dimensions are all in mm and are for hole or duct size.

## Fixing Details

The diagram below illustrates the standard mounting methods plus show the methods available for mitred sections.

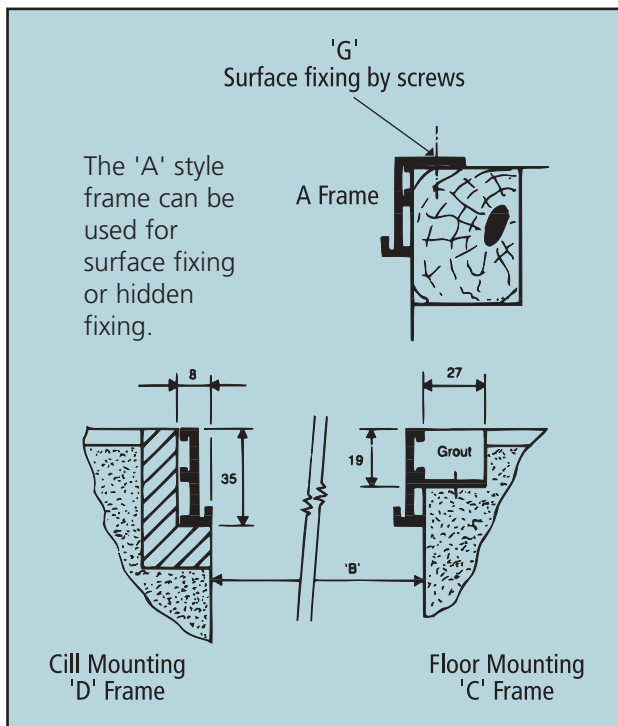

## Mitred Corners

Mitred corners are available, cut to any angle, and are all purpose made to special order. Available in three methods for cill, ceiling or sidewall applications. Standard leg length is 500mm over flange measured from inside of angle.

### Method E

#### Cill Flat Corner

NOT AVAILABLE WITH 'Y' and 'Z' cores  
Direction of air pattern to be advised when used with D cores.

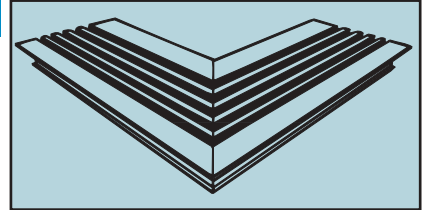

### Method F

#### Sidewall Outside Corner

NOT AVAILABLE WITH 'Y' and 'Z' cores;  
'D' and 'C' frames

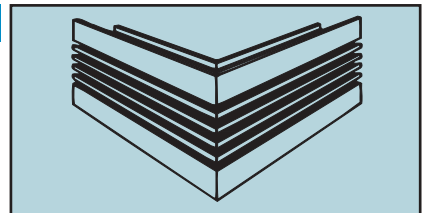

### Method G

#### Sidewall Inside Corner

NOT AVAILABLE WITH 'Y' and 'Z' cores;  
'D' and 'C' frames

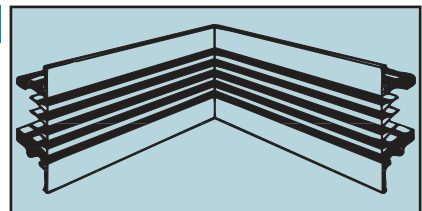

## Finish:

The grilles are available in a wide variety of finishes including standard BS and RAL powder coating or anodised aluminium. Please refer to the product coding section within this brochure for a list of standard finishes. Special finishes are available on request.

## Plenum Boxes:

Colman Moducel manufacture a range of high quality, galvanised sheet metal plenum boxes to suit the T series grilles. For supply air applications the plenums incorporate an equalising mesh to spread the air along the active length of the diffuser. Plenums are available in a standard configuration or purpose made to suit different ceilings, bulkheads or air volumes and are manufactured in lined and unlined versions. Standard plenum sizes are detailed within this brochure and plenums are supplied with a single circular entry spigot per plenum as standard however oval or rectangular versions are also available. Balancing dampers are available for the inlet spigot if required.

# ORDER CODES

## Diffuser Coding

FRAME	CORE TYPE	ACCESSORIES	ARRANGEMENT	FIXING	FINISH
<ul style="list-style-type: none"> <li><b>O</b> None</li> <li><b>A</b> 25mm surface</li> <li><b>C</b> Recessed frame</li> <li><b>D</b> Flangeless frame</li> <li><b>J</b> Computer floor grille</li> <li><b>1</b> Special</li> </ul>	<ul style="list-style-type: none"> <li><b>O</b> None</li> <li><b>C</b> 6.4mm bars @ 12.5mm centres</li> <li><b>D</b> 6.4mm bars @ 12.5mm centres with 15° deflection</li> <li><b>J</b> C core for computer floor grille</li> <li><b>Y</b> 3mm bars @ 12.5mm centres</li> <li><b>Z</b> 3mm bars @ 12.5mm centres with 15° deflection</li> <li><b>1</b> Special</li> </ul> <p><b>Note:</b> Y and Z cores cannot be used with C and D frames, or with mitred corners.</p>	<ul style="list-style-type: none"> <li><b>O</b> None</li> <li><b>V</b> Face operated volume control</li> <li><b>X</b> Opposed blade damper painted matt black</li> <li><b>1</b> Special</li> </ul> <p><b>Note:</b> When used with plenums mono-blade dampers would be our preferred option.</p>	<ul style="list-style-type: none"> <li><b>O</b> None</li> <li><b>A</b> Intermediate - no end caps</li> <li><b>B</b> Straight - 2 end caps</li> <li><b>C</b> Straight - R/H end cap</li> <li><b>D</b> Straight - L/H end cap</li> <li><b>E</b> 90° Mitred corner - Flat Ceiling mounted</li> <li><b>F</b> 90° Mitred corner - sidewall outside corner</li> <li><b>G</b> 90° Mitred corner - sidewall inside corner</li> <li><b>H</b> Mitred corner ceiling mounted angle to be specified</li> <li><b>J</b> Mitred corner sidewall outside corner angle to be specified</li> <li><b>K</b> Mitred corner sidewall inside corner angle to be specified</li> <li><b>1</b> Special</li> </ul>	<ul style="list-style-type: none"> <li><b>O</b> None</li> <li><b>H</b> Hanger bracket</li> <li><b>E</b> Spring clips</li> <li><b>G</b> Screw through flange</li> <li><b>X</b> Extended hanger bracket</li> <li><b>D</b> Universal extended bracket</li> <li><b>U</b> Universal mounting brackets</li> <li><b>1</b> Special</li> </ul> <p><b>Note:</b> All fixings detailed above are only applicable to 'A' frame.</p>	<ul style="list-style-type: none"> <li><b>B</b> Matt Black</li> <li><b>C</b> BS00E55 Gloss White</li> <li><b>D</b> BS00E55 Matt White</li> <li><b>E</b> RAL9010 Gloss</li> <li><b>F</b> RAL9010 Matt</li> <li><b>G</b> RAL9010 Satin</li> <li><b>H</b> BS00E55 Satin white</li> <li><b>A</b> Anodised colour to be specified</li> <li><b>O</b> Mill Finish</li> <li><b>3</b> RAL 9006 Aluminium</li> <li><b>9</b> Satin Anodised Aluminium</li> <li><b>1</b> Special</li> </ul>

## Plenum Coding

LINING	INSTALLATION METHOD	ACCESSORIES	ARRANGEMENT	SPIGOT TYPE	SPIGOT SIZE (DIA or SQ) (All in mm)
<ul style="list-style-type: none"> <li><b>L</b> Lined 6mm bestobell</li> <li><b>N</b> Unlined</li> <li><b>1</b> Special</li> </ul>	<ul style="list-style-type: none"> <li><b>O</b> None</li> <li><b>U</b> To suit A frame grille only</li> <li><b>1</b> Special</li> </ul>	<ul style="list-style-type: none"> <li><b>O</b> None</li> <li><b>M</b> Mono blade cord operated damper</li> <li><b>N</b> Mono blade cord operated damper painted matt black internally only</li> <li><b>P</b> Internally painted matt black</li> <li><b>1</b> Special</li> </ul> <p><b>Note:</b> Maximum size mono blade - 400 dia or 350 square.</p>	<ul style="list-style-type: none"> <li><b>E</b> Extract</li> <li><b>S</b> Supply</li> <li><b>1</b> Special</li> </ul>	<ul style="list-style-type: none"> <li><b>R</b> Round - side entry</li> <li><b>S</b> Square - side entry</li> <li><b>T</b> Round - Top entry</li> <li><b>W</b> Round - Flush with top of unit</li> <li><b>X</b> Square - Flush with top of unit</li> <li><b>Y</b> Square - top entry</li> <li><b>1</b> Special</li> </ul>	<ul style="list-style-type: none"> <li><b>A</b> 100</li> <li><b>B</b> 125</li> <li><b>C</b> 150</li> <li><b>D</b> 200</li> <li><b>E</b> 250</li> <li><b>F</b> 300</li> <li><b>G</b> 350</li> <li><b>H</b> 400</li> <li><b>J</b> 450</li> <li><b>K</b> 500</li> <li><b>L</b> 160</li> <li><b>M</b> 180</li> <li><b>N</b> 315</li> <li><b>P</b> 280</li> <li><b>R</b> 225</li> <li><b>S</b> 355</li> <li><b>T</b> 175</li> <li><b>1</b> Special</li> </ul> <p>All standard spigots 75mm deep</p>

## Example of Order Codes

T A C V B G F 1 2 0 0 1 5 0

- Linear Bar Grille -----
- 25mm Flanged Frame -----
- 6.4mm Bars @ 12.5mm Centres -----
- Face Operated Volume Control Damper -----
- 2 No End Caps -----
- Screw Fixed Through Flanges -----
- RAL 9010 Matt Finish -----
- Size - (Width x Height) -----

## Selection Information

The following selection data is applicable where normal temperature differentials exist in cooling and heating applications up to 11°C and a ceiling height of 2.7m. It is recommended that where two grilles are discharging

towards each other, selections are based on a diffuser air volume that will produce a maximum throw equal to half the distance between the two diffusers. The throw data is based on cill application with the grille mounted 2m below the ceiling. On applications where the distance is greater than this,

the throw is reduced by the amount of the variation.

For return air applications the data is based on a 0 deflection grille with the damper fully open. 15° blades have a 20% higher pressure drop and 1 NC higher sound rating.

**Table 1: Diffuser length correction figures**

Diffuser Length (m)	Factor	NC Correction
0.3	0.5	-2
0.6	0.85	-2
0.9	0.95	-1
1.2	1	0
1.5	1.05	+1
1.8	1.1	+2
2.1	1.13	+2
2.4	1.15	+3
2.7	1.16	+4
3.0+	1.17	+4

**Table 2: Spigot velocity against NC rating**

Sound Rating NC	Spigot Velocity m/s
25	2.5
30	3
35	3.5
40	4.5

**Selection factors:**

Throws are based on 1.2m active lengths, for different lengths use the factors in table 1 to determine the throw.

**Model TNU Plenum Box**

**Plenum Sizing:**

Plenum sizes shown in table 3 are the minimum recommended to give an even distribution across the diffuser using a centre fed constant cross-section box.

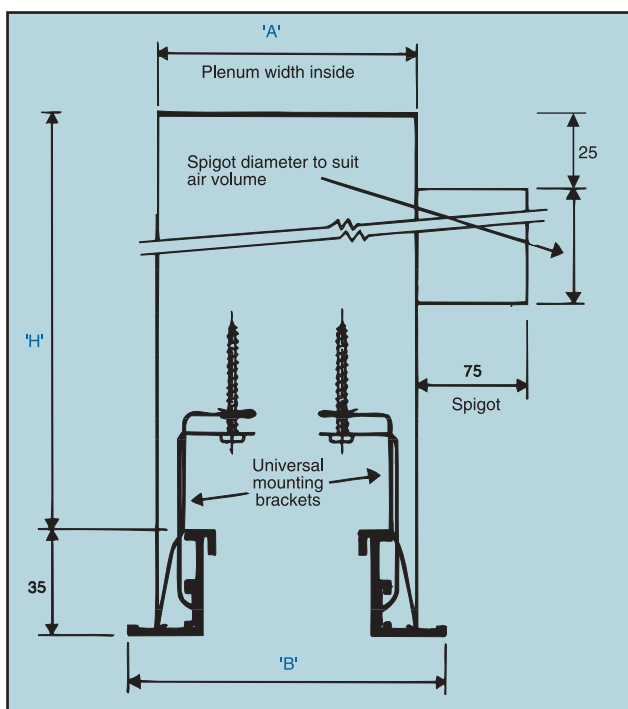

For return air applications when the grille is > 300mm in height, divide the air volume per metre by two and refer to a grille of half the height, add 3 NC to the sound ratings at this air volume.

**NC Data :**

All ratings are based on a room allowance (RA) of 8dB and are with dampers fully open. Measurements are based on the microphone being at 45° from the face of the grille with a distance of 1.5m. Dampers are fitted for fine tuning purposes, excessive damping to overcome high duct pressures will result in increased sound levels of approximately 8dB per doubling of pressure drop. NC ratings are based on 1.2m active lengths, for different lengths use the correction figures in table 1. The sound ratings only apply for lengths of 1.2m and if the inlet spigot is sized to give the indicated spigot velocity. The figures in table 2 are for guidance only and acoustic lining may be necessary plus an increase in plenum size.

**Air Velocities:**

When

Minimum throw = 0.40m/s  
Maximum throw = 0.15m/s

The average face velocities given are for the total area bounded by the frame and not the free areas of the slots between the bars.

Note: The figures given are in units of area per unit length, multiply these figures by diffuser active length to obtain total plenum box cross-sectional area.

The cross sectional area values are subject to alteration by physical requirements such as spigot location, spigot size and lining requirements.

**Table 3**

Plenum Cross Sectional Area (m <sup>2</sup> /m)			
Grille Model	Grille Height		
	100	150	
TAY	0.052	0.085	
TAC	0.038	0.061	
TAZ	0.052	0.085	
TAD	0.038	0.061	

Diffuser Nominal Height	A	B	H
100	113	132	Cross sectional area ÷ dim. 'A'
150	163	182	

## 'C' Core Supply

Air Volume m <sup>3</sup> /s/m	Throw m		Diffuser Height mm	Face Velocity m/s	Pressure Drop Pa	Sound Rating NC
	Min.	Max.				
0.039	1.1 - 1.5		50			-
0.101	1.7 - 2.2		100	1.25	3	-
0.164	2.2 - 2.9		150			-
0.047	1.3 - 1.7		50			-
0.122	2.1 - 2.6		100	1.50	4	-
0.197	2.8 - 3.7		150			-
0.054	1.5 - 2.1		50			-
0.142	2.5 - 3.1		100	1.75	6	-
0.229	3.2 - 4.2		150			-
0.062	1.8 - 2.4		50			-
0.162	2.8 - 3.6		100	2.00	7	-
0.262	3.8 - 4.9		150			-
0.070	2.0 - 2.7		50			-
0.182	3.2 - 4.0		100	2.25	9	-
0.295	4.3 - 5.5		150			-
0.078	2.2 - 3.0		50			-
0.203	3.5 - 4.5		100	2.50	11	-
0.328	4.8 - 6.2		150			-
0.085	2.4 - 3.3		50			-
0.223	3.9 - 4.9		100	2.75	14	-
0.360	5.3 - 6.8		150			-
0.093	2.7 - 3.6		50			-
0.243	4.3 - 5.4		100	3.00	16	-
0.393	5.6 - 7.5		150			-
0.101	2.9 - 3.9		50			-
0.263	4.7 - 5.8		100	3.25	19	-
0.426	6.3 - 8.2		150			22
0.109	3.1 - 4.2		50			-
0.284	5.0 - 6.2		100	3.50	22	-
0.459	7.0 - 8.9		150			23
0.116	3.4 - 4.5		50			19
0.304	5.4 - 6.8		100	3.75	25	22
0.124	3.6 - 4.8		50			21
0.324	5.7 - 7.2		100	4.00	29	24
0.132	3.8 - 5.1		50			22
0.344	6.1 - 7.6		100	4.25	33	25
0.140	4.0 - 5.4		50			24
0.365	6.4 - 8.1		100	4.50	37	28
0.147	4.2 - 5.7		50			27
0.385	6.8 - 8.5		100	4.75	41	29
0.155	4.4 - 6.0		50			23
0.405	7.0 - 8.8		100	5.00	45	31

## 'D' Core Supply

Air Volume m <sup>3</sup> /s/m	Throw m		Diffuser Height mm	Face Velocity m/s	Pressure Drop Pa	Sound Rating NC
	Min.	Max.				
0.047	3.0 - 3.5		50			-
0.122	3.9 - 4.3		100	1.5	5	-
0.197	4.2 - 5.1		150			-
0.054	3.2 - 3.8		50			-
0.142	4.2 - 4.7		100	1.75	7	-
0.229	4.5 - 5.5		150			-
0.062	3.4 - 4.1		50			-
0.162	4.5 - 5.0		100	2.0	10	-
0.262	5.0 - 6.1		150		21	-
0.070	3.4 - 4.3		50			-
0.182	4.9 - 5.5		100	2.25	12	20
0.295	5.3 - 6.6		150			25
0.078	3.7 - 4.5		50			-
0.203	5.2 - 5.9		100	2.5	15	22
0.328	5.7 - 7.0		150			30
0.085	3.9 - 4.8		50			-
0.223	5.5 - 6.2		100	2.25	18	24
0.360	6.1 - 7.6		150			33
0.093	4.0 - 5.0		50			22
0.243	6.8 - 6.6		100	3.0	22	27
0.100	4.2 - 5.2		50			24
0.263	6.2 - 7.0		100	3.25	26	30
0.109	4.3 - 5.5		50			25
0.284	6.5 - 7.4		100	3.5	30	33
0.116	4.5 - 5.8		50			28
0.304	6.8 - 7.7		100	3.75	34	37
0.124	4.7 - 6.0		50			29
0.324	7.1 - 8.1		100	4.0	39	39
0.132	4.9 - 6.3		50			31
0.140	5.0 - 6.5		50			33
0.147	5.2 - 6.8		50			36
0.155	5.4 - 7.1		50			37

## 'Y' Core Supply

Air Volume m <sup>3</sup> /s/m	Throw m		Diffuser Height mm	Face Velocity m/s	Pressure Drop Pa	Sound Rating NC
	Min.	Max.				
0.038 0.102 0.166	0.9 - 1.5 1.5 - 2.1 2.1 - 2.7	50 100 150	1.25	1		
0.046 0.124 0.200	1.2 - 1.8 2.1 - 2.7 2.4 - 3.4	50 100 150	1.50	2		
0.054 0.144 0.230	1.5 - 2.1 2.4 - 3.1 3.1 - 4.0	50 100 150	1.75	3		
0.064 0.164 0.266	1.8 - 2.4 2.4 - 3.4 3.4 - 4.6	50 100 150	2.00	4		
0.071 0.186 0.299	2.1 - 2.7 3.1 - 4.0 4.0 - 5.2	50 100 150	2.25	5		
0.079 0.206 0.333	2.1 - 3.1 3.4 - 4.3 4.3 - 5.8	50 100 150	2.50	6		
0.087 0.226 0.365	2.4 - 3.4 3.7 - 4.9 4.9 - 6.4	50 100 150	2.75	7		
0.094 0.246 0.399	2.7 - 3.7 4.0 - 5.2 5.2 - 7.0	50 100 150	3.00	8		
0.102 0.266 0.433	3.1 - 4.0 4.3 - 5.5 5.8 - 7.6	50 100 150	3.25	10	15	
0.110 0.286 0.464	3.1 - 4.3 4.6 - 6.1 6.1 - 8.2	50 100 150	3.50	11	15 24	
0.119 0.310	3.4 - 4.6 4.9 - 6.4	50 100	3.75	13	18	
0.127 0.330	3.7 - 4.9 5.2 - 7.0	50 100	4.00	14	19	
0.135 0.348	4.0 - 5.2 5.5 - 7.3	50 100	4.25	16	17 21	
0.142 0.386	4.1 - 5.5 5.8 - 7.9	50 100	4.50	18	18 22	
0.150 0.390	4.3 - 5.8 6.1 - 8.2	50 100	4.75	20	20 23	
0.158 0.410	4.6 - 6.1 6.4 - 8.8	50 100	5.00	23	21 26	

## 'Z' Core Supply

Air Volume m <sup>3</sup> /s/m	Throw m		Diffuser Height mm	Face Velocity m/s	Pressure Drop Pa	Sound Rating NC
	Min.	Max.				
0.038 0.102 0.166	1.5 - 2.1 1.8 - 2.7 2.7 - 3.7	50 100 150	1.25	1		
0.046 0.124 0.200	1.2 - 2.4 2.4 - 3.4 3.1 - 4.3	50 100 150	1.50	2		
0.054 0.144 0.230	2.4 - 2.7 2.7 - 4.0 3.7 - 5.2	50 100 150	1.75	3		
0.064 0.164 0.266	2.4 - 3.4 3.1 - 4.3 4.3 - 5.8	50 100 150	2.00	4		
0.071 0.186 0.299	2.7 - 3.7 3.7 - 4.9 4.9 - 6.7	50 100 150	2.25	5		
0.079 0.206 0.333	3.1 - 4.3 4.0 - 5.5 5.5 - 7.3	50 100 150	2.50	6		
0.087 0.226 0.365	3.3 - 4.6 4.6 - 6.1 6.1 - 8.2	50 100 150	2.75	7		
0.094 0.246 0.399	3.7 - 4.9 4.9 - 6.7 6.4 - 8.8	50 100 150	3.00	8		
0.102 0.266 0.433	4.0 - 5.5 5.2 - 7.0 7.0 - 9.7	50 100 150	3.25	10	15	
0.110 0.286 0.464	4.3 - 5.8 5.8 - 7.6 7.6 - 10.4	50 100 150	3.50	11	15 24	
0.119 0.310	4.6 - 6.4 6.1 - 8.5	50 100	3.75	13	18	
0.127 0.330	4.9 - 6.7 6.4 - 8.8	50 100	4.00	14	19	
0.135 0.348	5.2 - 7.0 7.0 - 9.4	50 100	4.25	16	17 21	
0.142 0.386	5.5 - 7.6 7.3 - 10.1	50 100	4.50	18	18 22	
0.150 0.390	5.8 - 7.9 7.8 - 10.7	50 100	4.75	20	20 23	
0.158 0.410	6.1 - 8.2 8.2 - 11.3	50 100	5.00	23	21 26	

## 'T' Series Return

Air Volume m <sup>3</sup> /s/m	Grille Height mm	Face Velocity m/s	Cores 'C' & 'D'		Cores 'Y' & 'Z'	
			Pressure Drop Pa	NC	Pressure Drop Pa	NC
0.12	100					
0.20	150					
0.28	200	1.5	6		3	
0.35	250			17		
0.43	300			18		
0.14	100			22		20
0.23	150			18		
0.32	200	1.75	9	20	4	
0.41	250			21		16
0.50	300			22		16
0.16	100			24		23
0.26	150			21		17
0.37	200	200	11	24	5	17
0.47	250			25		19
0.58	300			26		20
0.19	100			28		25
0.30	150			24		20
0.41	200	2.25	15	28	6	21
0.53	250			28		22
0.58	300			29		23
0.21	100			29		27
0.33	150			27		22
0.46	200	2.50	18	29	7	24
0.59	250			30		25
0.72	300			31		26
0.23	100			30		28
0.37	150			30		25
0.51	200	2.75	22	32	9	26
0.67	250			33		27
0.79	300			34		28
0.25	100			32		30
0.40	150			33		27
0.55	200	3.00	26	35	12	29
0.71	250			36		30
0.86	300			37		33
0.26	100			34		31
0.43	150			36		28
0.60	200	3.25	30	37	14	31
0.77	250			38		32
0.93	300			39		41
0.28	100			36		32
0.46	150			38		30
0.65	200	3.50	36	40	17	14
0.83	250			41		37
1.04	300			42		44

## LINEAR BAR GRILLES

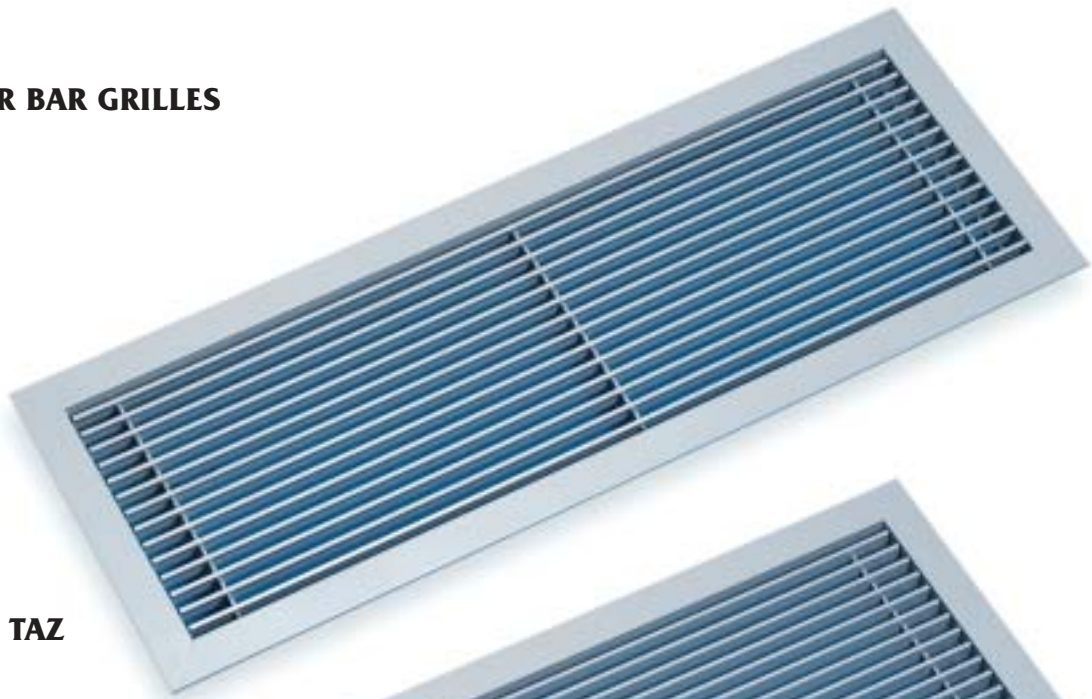

**Model TAZ**



**Model TAY**



**Model TCC**

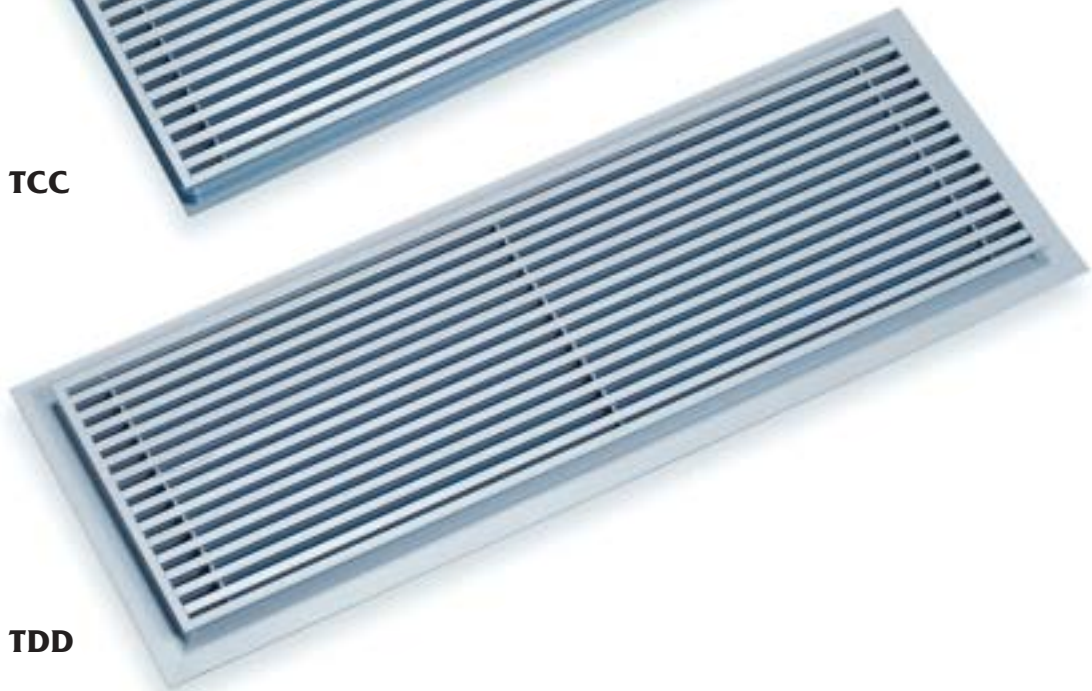

**Model TDD**

# MODEL TJJ COMPUTER FLOOR GRILLE

## Instructions for use of graph

Select air volume required on lower edge of main graph. Read vertically downward on to bottom scale for air velocity. Trace a line vertically upward until required grille line is required. Read off horizontally to the left for pressure drop.

TJJ0/TJJV  
**Extract** —  
 TJJ0/TJJV  
**Supply** - - -

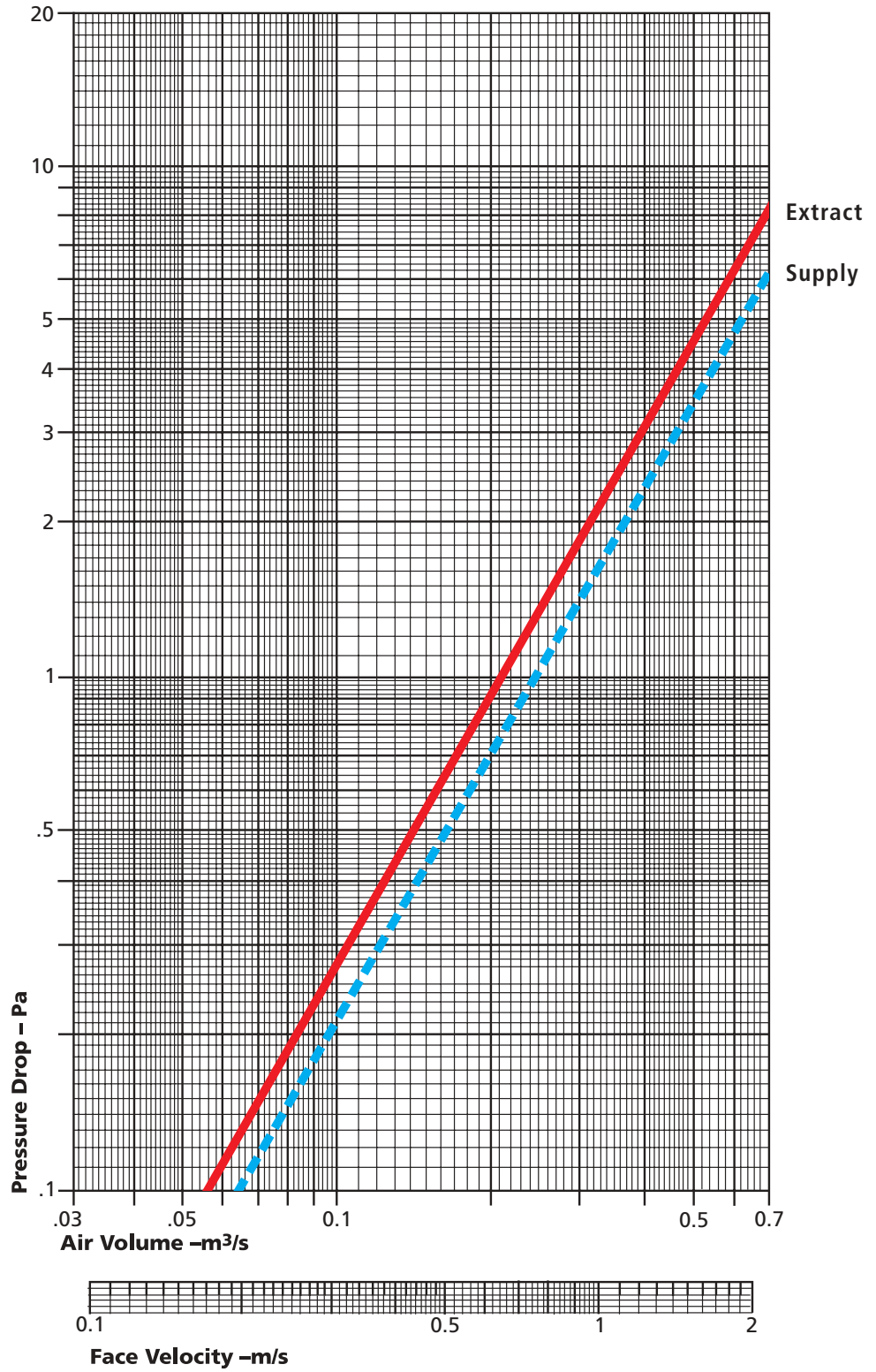

# PRODUCT RANGE

## AIR HANDLING UNITS

PACKAGED AIR CONDITIONING UNITS

SPLIT SYSTEM AIR CONDITIONING UNITS

## TERMINAL PRODUCTS

Fan Coil

VAV

Constant Volume

Induction

Fan Assisted VAV

HEAT RECOVERY PLANT

HEAT PUMPS

CONTROL SYSTEMS

REFRIGERATION

DAMPERS

FILTERS

## DIFFUSERS

Linear Slot

Louvre Face

Sidewall

Perforated Face

Vee Face Two Way

Circular

Swirl

Ceiling

Sidewall Fixed and Adjustable

Jet Flow

## ACOUSTIC PRODUCTS

Attenuators

## DISPLACEMENT

## GRILLES

Linear Bar

Ceiling

Sidewall

Floor

Computer Floor

Cill

Single and Double Deflection

Egg Crate

Hinged Core

Door Transfer

Security and Prison

## LOUVRES

External

Circular

Door

Screens

Penthouse

Acoustic



Air Distribution and Air Handling

Oldfields Business Park  
Birrell Street, Fenton  
Stoke-on-Trent ST4 3ES  
Telephone: +44 (0)1782 599995  
Facsimile: +44 (0)1782 599220  
email: colman.moducel@eaton-williams.com



Eaton-Williams

Station Road, Edenbridge  
Kent TN8 6EG, England  
Telephone: +44 (0)1732 866055  
Facsimile: +44 (0)1732 869626  
www.eaton-williams.com